

A Practical Guide to

# **Wheel Building**

3<sup>rd</sup> Edition

Roger Musson

## **A Practical Guide to Wheel Building 3**

Thank you for purchasing this book. The book represents a factual account of how I build wheels and is provided in the hope that it is useful.

I am obliged to write the following terms and conditions for use of the book and if you disagree with anything below then please contact me and I'll refund your purchase.

1. If you have any doubts about your own ability and mechanical skills then consult a qualified cycle mechanic before attempting any of the procedures contained in the book.
2. The book and any related materials are provided "AS IS" and without warranty of any kind and the Author expressly disclaims all other warranties, expressed or implied, including, but not limited to, the implied warranties of merchantability and fitness for a particular purpose. Under no circumstances shall the Author be liable for any incidental, special, or consequential damages that result from the information contained in this Book.
3. **Please do not give copies to friends**, it's not expensive so please ask them to purchase their own copy. If you are reading a copy that you obtained without paying then please go to **[www.wheelpro.co.uk](http://www.wheelpro.co.uk)** and make a purchase and obtain the most up to date version.

Unauthorised distribution, duplication, or resale of all or any portion of this book is strictly prohibited. No part of this book may be reproduced, stored in a retrieval system, shared or transmitted in any form or by any means, without the prior written permission of the Author, except in the case of brief quotations embodied in articles or reviews.

BY USING THIS BOOK, YOU ARE AGREEING TO BE BOUND BY THE TERMS OF THIS AGREEMENT. IF YOU DO NOT AGREE TO THE TERMS OF THIS AGREEMENT, DO NOT USE THE BOOK AND DESTROY ALL COPIES IN YOUR POSSESSION.

Copyright © Roger Musson 2005-2006 3.05

# CONTENTS

<b>1. Introduction .....</b>	<b>5</b>
<b>2. Components and Features .....</b>	<b>7</b>
Rims - spoke holes .....	7
Rims – eyelet design .....	8
Hubs .....	9
Downhill wheels .....	10
Spokes .....	10
Spoke threads .....	13
Inside and outside spokes .....	13
Spoke orientation.....	13
Nipples.....	14
Wheel trueness .....	15
Wheel dish.....	16
Dishless frames and wheels.....	16
<b>3. Tools .....</b>	<b>17</b>
Spoke wrench.....	17
The wheel jig .....	18
Wheel dishing gauge.....	25
The nipple driver.....	28
Leather gloves .....	30
CX-Ray tool .....	31
Nipple holder .....	31
Chain whip.....	32
<b>4. Building.....</b>	<b>33</b>
Lubricants and Adhesives .....	33
Lacing the Wheel.....	35
Completing the wheel .....	45
Wheel tolerances.....	55
How long should it take .....	56
Testing your wheel .....	56
<b>5. Repairing .....</b>	<b>58</b>
Checking the wheel .....	58
Loose spokes .....	59
Damaged spokes .....	59

Spoke breakages .....	60
Rim wear and damage .....	60
Hub damage .....	61
Dismantling an old wheel.....	62
Lateral truing.....	65
<b>6. Wheel Designs .....</b>	<b>68</b>
Standard crossed wheels .....	69
Tying and soldering .....	70
Radial wheels .....	71
Cross combinations on the same wheel.....	71
Inside or outside pulling spokes .....	72
Other lacing patterns .....	74
Missing out hub and rim holes.....	74
Number of spokes .....	74
Design considerations - the Last Word .....	74
Warning.....	75
<b>7. Spoke Lengths .....</b>	<b>76</b>
1. A different hub .....	76
2. A different rim (on a hub you've previously built).....	77
The spoke length formula.....	79
<b>8. Measuring rims.....</b>	<b>83</b>
<b>9. Measuring hubs.....</b>	<b>85</b>
<b>10. The Geometry of a wheel.....</b>	<b>88</b>
<b>11. Wheel building checklist .....</b>	<b>92</b>
<b>12. And finally... ..</b>	<b>93</b>

# 1. Introduction

For many people their cycle maintenance routines stop when it comes to tackling wheels. Retruing, replacing a spoke or building them is something for the experts to sort out. There is certainly a great deal of mystique surrounding the art of wheel building and this is reinforced by the reclusive life the wheel builders tend to inhabit. You rarely see these people at work, they rarely discuss their techniques in any detail, very little is written down and the cyclist can easily get the impression that wheelbuilding is a difficult skill to learn.

Building wheels is not difficult and there's certainly no artistic interpretation. Building wheels is a standard mechanical procedure of assembling and tightening spokes in the correct sequence and that's all. Building a wheel does though require patience and attention to detail if you want to build a pair of top quality wheels that will certainly be as good as, and more likely better than anything you can purchase.

It's not expensive either. It's cheap to start and there are some great savings to be made once you start building a few wheels. It's very satisfying picking up a hub and rim from the closeout sale, or choosing a hub from the lower end of the groupset hierarchy matched up with a similarly 'ordinary' rim and knocking up some wheels that are terrific. And when your rims wear out it's a simple task of replacing the rim. But you are not doing this to save money, you are doing it because you want the best set of wheels possible all of the time, and when it comes to wheels only one-thing matters – how well they are built.

Once you have built your first wheel and are comfortable with the techniques involved you will become independent and never have to rely on the cycle shop or worry about finding a competent wheel builder. You will also have total control over the build quality and when the work is carried out and many people will become fascinated by this branch of cycle mechanics.

This book will show you how to build bicycle wheels using the methods that I use. It describes the tools and techniques and covers the design aspects that are relevant to cyclists and cycle mechanics. It is entirely suitable for people with no previous wheel building experience and for regular wheel builders who would like to see how someone else tackles the subject.

The information provided in this book is based on my wheelbuilding experiences over many years that started out building wheels for my own use, followed by owning a business that specialised in custom wheelbuilding. Part of the business activity was to sponsor professional race teams where I looked after all the wheel related issues from the initial build to ongoing servicing at race events, I also ran wheelbuilding courses and did wheelbuilding demonstrations at cycle shows.

Wherever possible the text concentrates on the practical approach to building wheels and keeps away from any technical issues that would otherwise confuse a relatively straightforward process. The book is presented in a logical order and it is advisable to read it from start to finish before homing in on the areas of particular interest. If you are new to wheel building then some sections may need reading a few times to gain a good understanding.

Don't be put off by the amount of information I've given you. Wheelbuilding is not difficult and I could have summarised and slimmed the book down considerably but I'm sure you wouldn't want that. You are getting the full and complete story with nothing left out.

The diagrams in this book are drawn using CAD software and although easily readable on-screen they will be sharp and extremely clear if printed and I recommend you print the book. For best effect print double sided, ie. print the odd pages then replace in the printer and print the even pages. Consult your printer manual or try a couple of test pages to check the correct orientation before printing the whole book. The colour photographs are best viewed on-screen.

The book you are reading here is the 3<sup>rd</sup> edition. Editions 1 and 2 (a reprint) were hard copy books that I wrote in 1996 while I worked in engineering at Rockwell Graphic Systems (manufacturers of newspaper printing machines). This one brings it all up to date with all my experiences from my life as a professional wheelbuilder.

Over the years in the wheelbuilding business I've met many people who were kind enough to offer help and advice. So a big thanks to the following: *Chicken and Sons* (UK importer of Sapim spokes), Martine Lambrecht (the then owner of Sapim), everyone at *Hope Technology*, Editors and Journalists at many UK cycling magazines, race team managers and their team riders. Thanks.

A forum is available at [www.wheelpro.co.uk/forum/](http://www.wheelpro.co.uk/forum/) to discuss the book and any questions you may have. The forum will also be used to post any book modifications.

Thanks for purchasing this book.

Roger Musson

Email: [rm@wheelpro.co.uk](mailto:rm@wheelpro.co.uk)

## 2. Components and Features

There are a number of features of the wheel and its components that are particularly important in the wheel building process and these should be understood and identified before commencing.

### Rims - spoke holes

The spoke holes in the rim are usually offset alternate left and right and this is obvious on most rims. Others though will require a closer observation to reveal the offset and some rims will have no offset at all with the holes positioned centrally. It is important to identify the offset because it is significant in the lacing process since left orientated rim holes have their spokes connected to the left hub flange and vice-versa.

Look carefully on the inside of the rim (Figure 1) at the holes either side of the valve hole (shown in black), and note how there are two possibilities for a rim with offset holes. It doesn't matter which way up the rim is because the offset orientation will not change.

Type 1 rims are by far the most common but check all the same. In all my years wheelbuilding I have only ever seen a couple of type 2's and they were on some old obscure rims. The one that can catch you out is where the rim holes are drilled on an angle (Figure 2) and was a common feature on Campagnolo rims where the rims had the look of a type 2 but were in fact type 1.

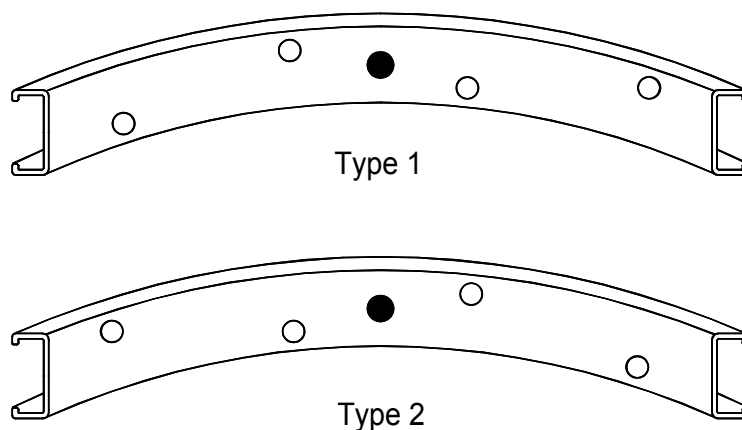
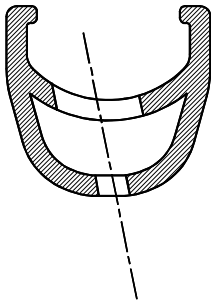


Figure 1 Rim types



It is not advisable to look into the rim channel from the outside because some manufacturers drill the rim holes at an angle to allow a natural spoke line between rim and hub and looking into the channel the offset may appear on the opposite side to which it actually is. Holes that are drilled on an angle, particularly on the “V” section rims, may appear central, but if in doubt, or you want to see the effect of the angle, pass a spoke through the rim and attach a nipple and you will soon see the natural line as you pull on the spoke.

Figure 2 Rim holes drilled on an angle

## Rims – eyelet design

The three types of eyelets are shown in Figure 3. The rim with no eyelets has plain drilled holes through the rim and the single eyelet design is just a simple collar around the spoke drilling.

The double eyelet design can be used on the deeper section rims that incorporate a closed box section, the double eyelet includes a secondary collar forming a cup that completely encloses and seals the rim drilling. With the double eyelet it’s a strength/durability issue because the spoke load is distributed across two faces of the rim but from your point of view it comes in handy when lacing the wheel because there is no chance of you dropping the nipple into the rim box section (there’s a tip in the building section to help prevent you doing this).

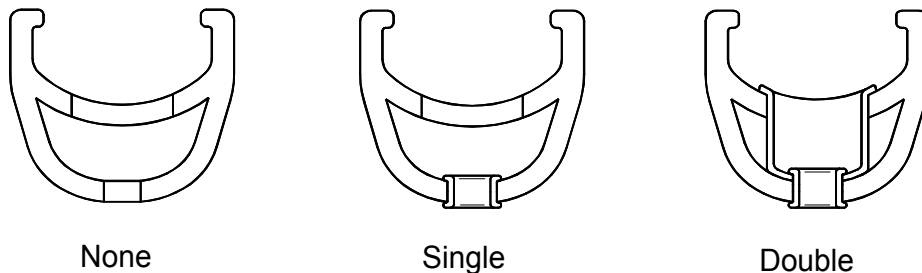


Figure 3 Rim eyelets

Choosing which eyelet design is not really a consideration for the builder, the rim manufacturer has made the choice for the particular rim and there is little difference when it comes to building either type.

If you are using coloured aluminium nipples with a rim with *no eyelets* then the sharp edges of the rim hole will scratch the surface colour of the nipple as it is tightened. The sharp edge of the non eyeleted rim can also gouge aluminium nipples and cause the nipples to fail later in use and is a consideration if you need ultra reliable wheels, in which case choose a rim with eyelets and use brass nipples.

## Hubs

Here are a few wheelbuilding related things to look out for on hubs.

Throughout this book I use the term *drive side* to describe the side of the rear hub that takes the sprockets, either cassette sprockets or threaded to take a freewheel. The *non drive side* is opposite the drive side. An alternative terminology is to use *left* and *right* where right is the drive and comes in useful for describing front disc brake hubs where the rotor is on the left – unless like me you use the term *disc side*! To avoid ambiguity the online spoke calculator ([www.wheelpro.co.uk](http://www.wheelpro.co.uk)) labels the sides up accordingly once you tell it what type of hub you are using.

The spoke holes on opposing flanges are offset radially half a hole pitch relative to each other. Each hole on one side will have associated with it two holes on the opposite side, one to the left and one to the right. This can be seen by visually sighting across the hub and it is important when building a wheel that you can spot this, if you are still unsure then look at Figure 35 on page 38 in the wheel building section.

The spoke holes will usually be countersunk to accommodate the *elbow* of the spoke. Countersinking is not an important consideration on aluminium flanges since the spokes will bed themselves into the softer material regardless of any countersinking. In fact some hubs that have alternate holes countersunk would seem to prevent certain lacing patterns if you always tried to get the elbow on the countersunk side, so do not worry about it on aluminium flanges.

The thickness of the hub flange should adequately support the spoke elbow. Very thin flanges can lead to increased spoke breakages and one solution to help prevent this is to use a small brass washer as packing between the head of the spoke and the hub flange (see Figure 4). This was common on old generation hubs, often with thin steel flanges but all of today's aluminium hubs have adequate flange thickness that makes the use of washers unnecessary.

There was another reason for using washers when DT changed the design of their spoke elbows back in 2000. This is described in detail on Peter White's website at [www.peterwhitecycles.com/DTspokes.htm](http://www.peterwhitecycles.com/DTspokes.htm) DT soon reverted back to normal elbows making the use of washers unnecessary. The key thing to remember is that the spoke elbow should be adequately supported and if necessary use washers supplied by the spoke manufacturer. I have always used modern hubs with Sapim or DT's current spokes so have never used washers.

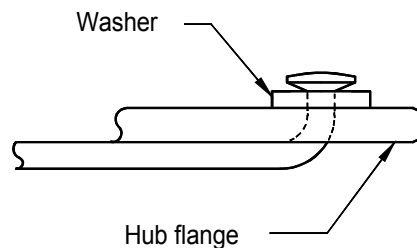


Figure 4 Using washers as packing

## Downhill wheels

From this point forward I'll occasionally mention the term *downhill wheels*. If you are a road cyclist then this will need some explaining. Downhill racing is a very specialised form of off-road riding where you get taken to the top of a mountain (or big hill) and your descent is timed over a marked course. The courses are rough and rocky with plenty of jumps, the bikes are very sophisticated and the wheels need to be tough. I built the wheels for many race teams and spent most weekends at a downhill event. Being involved with the teams gave me some unique feedback on how the wheels performed at the highest level of professional racing. I knew the bikes (and wheels) would be taking a beating though some very aggressive riding and after each race I would carefully examine each wheel to check the condition. They were perfect and it just confirmed my thoughts about wheelbuilding in general.



Figure 5 A downhill bike

So what's special about building a downhill wheel? Actually nothing at all, I build **all** wheels exactly the same way – whether they are for downhill racing or road time trialling. What I'm saying is that you don't build wheels different for different applications, all that changes is the hubs and rims and in the case of downhill wheels that meant some exotic hubs that required a suitable wheel jig to hold them.

Whilst at the races I tended to fix other people's wheels so I've fixed many broken and out of true wheels, I've scrutinised the building techniques (good and bad) of other wheelbuilders and I think I've seen most things that can happen to a wheel.

Pictured right from a few years back is Steve Jones from the Intense-Kawasaki team racing here in a UK National event at Cheddar (Hope Bulb hubs, Mavic D521 rims, 32 Sapim Race spokes per wheel (in black, with black brass nipples). Steve now works on the editorial team at Dirt magazine ([www.dirtmag.co.uk](http://www.dirtmag.co.uk))

## Spokes

Within reason, any hub and rim will do but spokes need to be the **best you can get** (quality wise – I'll discuss shape next). Use spokes made from stainless steel and don't be tempted by weight saving titanium spokes. Although I have no experience of using titanium spokes I understand that this material is not good for spokes and compared to steel it has lower strength, less stiff, and more friction in the threads when tightening the nipples, plus they are made in plain gauge (see below why this is not good). So you will (I hope) be using stainless steel.

Don't assume that spokes from different manufacturers that use *stainless steel* are equal. This is not always the case because the quality and grade of the steel can be different, the manufacturing process can be different plus many other factors that can yield an apparently cheap stainless steel spoke that is half the price of another brand. It really does pay to get the best because they are easier to build with and you end up with a more reliable and stronger wheel. I'm not going into detail why cheap spokes make poor wheels – trust me on this.

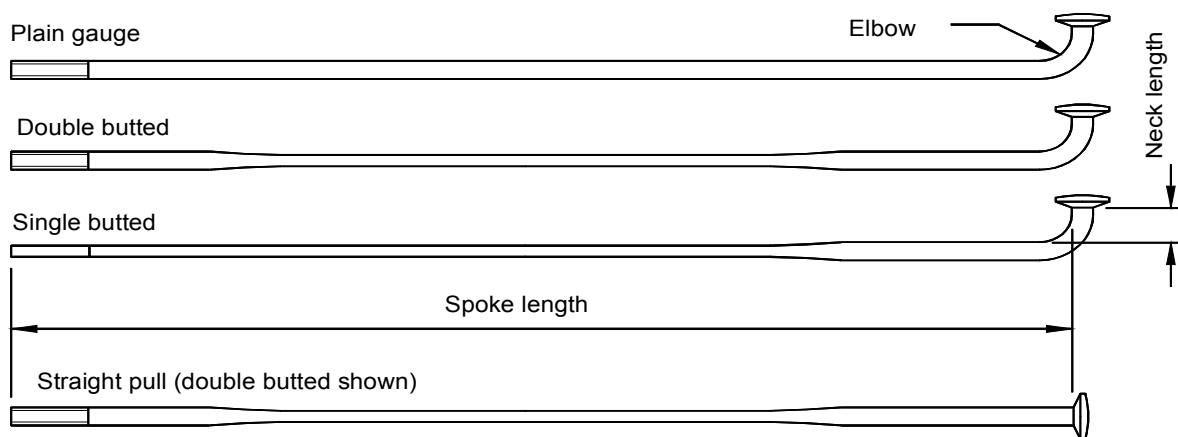


Figure 6 Spoke types (not to scale)

There are dozens of different types of spoke to choose from so we'll discuss the options then narrow the field down to one or two. The common types of spokes are shown in Figure 6.

Plain gauge spokes have a constant diameter of 2mm along the length of the spoke. They are the cheapest and also the easiest to build with since they are less likely to twist when tightening. The plain gauge spoke may look and feel stronger than a double butted spoke but if either are going to break then it will be at the spoke elbow or the spoke threads where both spokes are identical in diameter. Yet I still see adverts for handbuilt wheels that say "*built with plain gauge spokes for strength*". All the wheels for the Pro downhill riders that I built used 32 double butted spokes.

A double butted spoke has a central portion of a reduced diameter. The central portion is not cut or shaved but made via a forging process where the spoke goes through a pair of rollers that squeeze the metal (I believe DT use a different method of forging the central portion). The thinner central portion of the butted spoke will stretch slightly when building and the cyclic changes in tension on the spoke as you ride the bike will be absorbed within this region rather than generating high cyclic loads on the spoke elbow and threads giving rise to fatigue issues (fatigue is where high cyclic concentrated loads cause the metal to slowly crack). The inbuilt "stretch" will also ensure that the spoke does not become totally unloaded allowing the nipple to unscrew and the spoke to loosen. The standard double butted spoke is 2mm – 1.8mm – 2mm and the lightweight version is 2mm – 1.5mm – 2mm (other dimensional versions also exist). The lighter versions build wheels that are just as strong as those built with standard double butted spokes and you aim to build the wheel with the same tension but you will find they twist more and are therefore more troublesome to build with, especially in the longer road lengths. Don't get taken in with weight saving because the effects are negligible and other things can happen to lightweight spokes (page 59).

Spokes "designed" for heavy loads are of the single butted type where the diameter is constant for the majority of its length at 2mm but with an increase in diameter to 2.3mm towards the spoke elbow. If using these then make sure they will pass through the spoke holes in the hub. These spokes are non commonly available but in any case, the standard double butted spoke is more than adequate. I've never used these fat single butted spokes.

The straight pull spoke is becoming popular on factory built wheels where claims for additional strength are often made. However all you will be hearing is *sales and marketing speak* because they offer no advantage over standard spokes. The straight pull design is not a cure for spoke breakages either since they are just as susceptible to fatigue failure as conventional spokes. Hubs must be specifically designed to take the straight pull spoke and since you cannot readily purchase these (or the spokes) there is no point in worrying about them. There is nothing special in the manufacturing process of straight pull spokes, in fact they are cheaper to make because they just take them off the spoke making machine one stage early, before they receive the thump that bends over the elbow (making spokes is quite a brutal process with lots of thumping and banging).

Spokes come in cross sectional profiles other than round, typically the flat bladed spoke. These bladed spokes start life as a plain gauge spoke that are flattened (another thump) so they have the inherent disadvantages of the plain gauge spoke but they do look fast and *racey* although it's debatable whether the aero effects make any real difference. Make sure they can pass through the holes in your hub. Hub holes must be slotted for bladed spokes and this is preferably done by the hub manufacturer who has the

appropriate tooling. If you decide to slot the hubs yourself using needle files or whatever then take care not to remove too much material and not to leave any sharp corners which could start the propagation of a crack. Try to look at a factory slotted hub before attempting to slot your own hub. Modifying a hub will invalidate any warranty on the hub. I have never slotted a hub. The exception here is the CX-Ray spoke made by Sapim where they forge a double butted spoke (the 2mm – 1.5mm – 2mm variety) to give a very thin section of 0.9mm x 2.3mm which will pass through a standard drilled hub. They are *very* expensive and twist like crazy when building (I have a tool to help with this, more later in the tool section). Don't even think about putting CX-Ray's in mountain bike wheels because they will make zero difference in aero effect or wheel strength. On road race wheels the difference in aero performance is negligible but is noticed by some top road racers, but I cannot tell any difference.

Spokes last a long time and providing you take care of them when building and limit any damage to them when using the wheel the spokes can be re-used many times and will easily outlast many rims. And neither do you *retire* your spokes after they've done a certain mileage. As far as spokes go, if they are still in one piece then keep using them because they will be in perfect condition. There is a proviso here; I only reuse spokes if the original wheelbuild was my own (more about this on page 63)

So what do I use? You've probable guessed by now that it's the standard double butted spoke, certainly in my own personal wheels, team issue wheels and the vast majority of customer wheels. Some people tough it out and ask for the lighter double butted spokes and I build a few with CX-Ray spokes for the road racing guys. I stay with one manufacturer and use Sapim spokes. I couldn't use several manufacturers because I would be vastly increasing my already large stock holding where my main spoke is the *Sapim Race* in 1mm increments – imagine duplicating those sizes with say *DT Competition* (another excellent spoke).

The main problem for the new wheel builder is getting the correct length spokes and this is discussed in more detail later in the book.



Figure 7 Sapim straight pull spokes

## Spoke threads

Spoke threads are not cut, they are rolled where the thread is forged into the bare spoke. You can see this because the thread diameter is slightly greater than the spoke body diameter as the threads have bulged out slightly. Forging the thread makes it stronger and less prone to fatigue failure. Some people like to obtain the appropriate spoke lengths by cutting their own thread into spoke blanks (or from a trimmed down threaded spoke). This is not good because you are using a metal removal cutting process and not a forging one resulting in fatigue issues with the spoke. Some very expensive tools are available for rolling the threads but either way it's difficult to do because stainless steel is a tough material. Cutting and threading is also a laborious job so take the easy route and buy your spokes at the correct length and in doing so get a better spoke.

## Inside and outside spokes

Inside spokes have their elbows on the inside of the hub flange and outside spokes on the outside shown in Figure 8. A feature of the outside spokes is the excessive bows these spokes take when connected between hub and rim. This can be seen by taking a hub and passing a spoke through to the outside then pulling the threaded end gently inwards towards the hub centre line. These bows that appear to pull straight when the spoke is tensioned are detrimental to the spokes life and will be catered for at the building stage (aligning the spokes). Try the same with an inside spoke and notice how these can easily swing into the central position with little or no bowing.

Wherever possible you lace all the inside spokes first then lace the outside ones. This reduces the amount of spoke tangles when placing the spokes and will be better appreciated when you start lacing wheels.

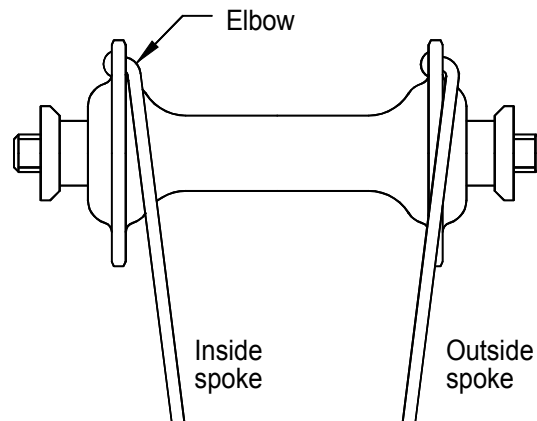


Figure 8 Inside and Outside spokes

## Spoke orientation

You should be able to identify two distinct spoke orientations in a cross laced wheel, spokes that radiate backwards (pulling) and spokes that radiate forwards (pushing) as shown in Figure 9. The name given to these is unimportant and you will often hear other terms to describe them. Rather than worry about what they are called just make sure you can spot them.

It becomes more significant in the building process where you have the option of placing the pulling spokes on the outside of the hub flange or on the inside. It is also one of the observations you will make when examining other people's wheels (the other habit you are guaranteed to form is to give their spokes a gentle squeeze to see how tight they are).

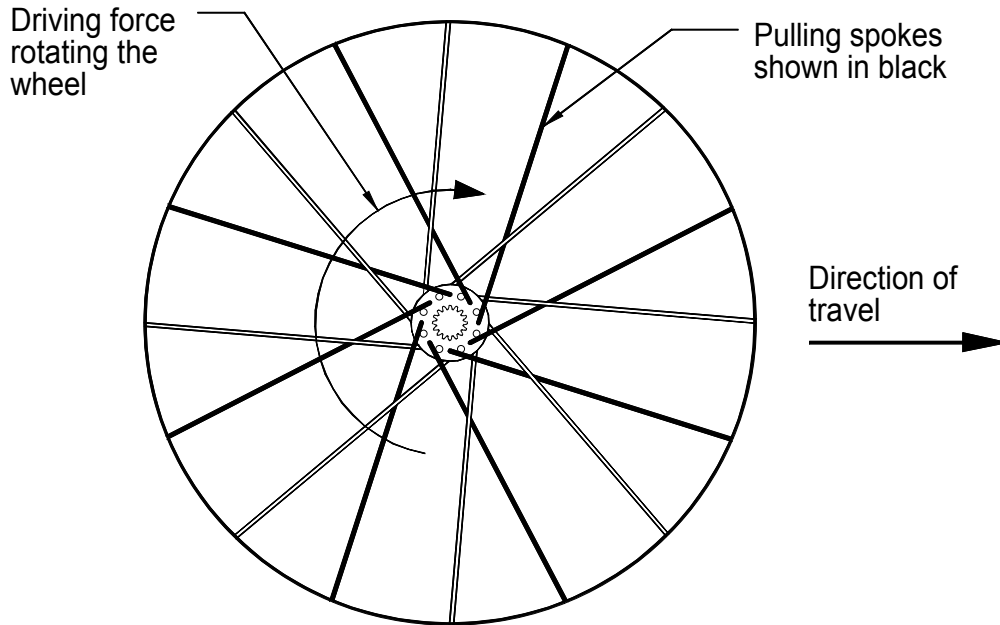


Figure 9 Pulling spokes

## Nipples

Brass nipples will come as standard with the spokes and are the best choice for all wheels. They are made from brass and nickel plated to give the silver finish. For purely cosmetic purposes some manufacturers will produce a black finish brass nipple. Standard nipples have an overall length of 12mm but on thicker rims they may not protrude enough through the rim to get the wrench on and for this condition the longer 14mm and 16mm nipples exist. Brass nipples are tough enough to be re used several times.

An alternative to brass are aluminium nipples and wrongly called *alloy* (brass is a better example of an alloy because brass is made from copper + zinc). When using aluminium nipples it is advisable to use a wrench that grips on four sides of the nipple to avoid rounding the corners of the nipple and also prevent shearing it (snap by twisting). You should tighten the nipple to the same tension you would use for the brass nipple. Yes you will save a few grams in weight but you won't notice any difference when riding. In extreme conditions they can fail. A race mechanic and someone I assumed to be a good wheelbuilder made a bad choice by building a set of downhill wheels for his professional rider using aluminium nipples which I can only guess was for cosmetic reasons. At a regional race, a friend of the Pro rider had borrowed one of his bikes for the day and mid way through the day he came to me with a wheel that needed fixing due to failed nipples where the heads of the nipples had popped off on several spokes. The nipples in use were not the standard 12mm variety but a slightly longer one. Now it could be due to the those particular nipples not being tough enough (i.e. aftermarket, poor quality) or some bad building technique, or the fact that the longer nipples were prone to twisting when building

and were left in a semi sheared state. Who knows? But I would never use aluminium nipples for a Pro downhill rider. They are perfectly okay for road race and MTB cross country where I sometimes use aluminium nipples from the spoke manufacturers but given a choice I always use brass nipples and if you want long term durable wheels then brass should be your choice too.

## Wheel trueness

The three aspects of a true wheel are shown in Figure 10. The wheel shown is a perfect wheel with no errors. In reality this is very difficult, if not impossible to achieve and a certain amount of error is inevitable (this is discussed in more detail in *Wheel tolerances*, page 55).

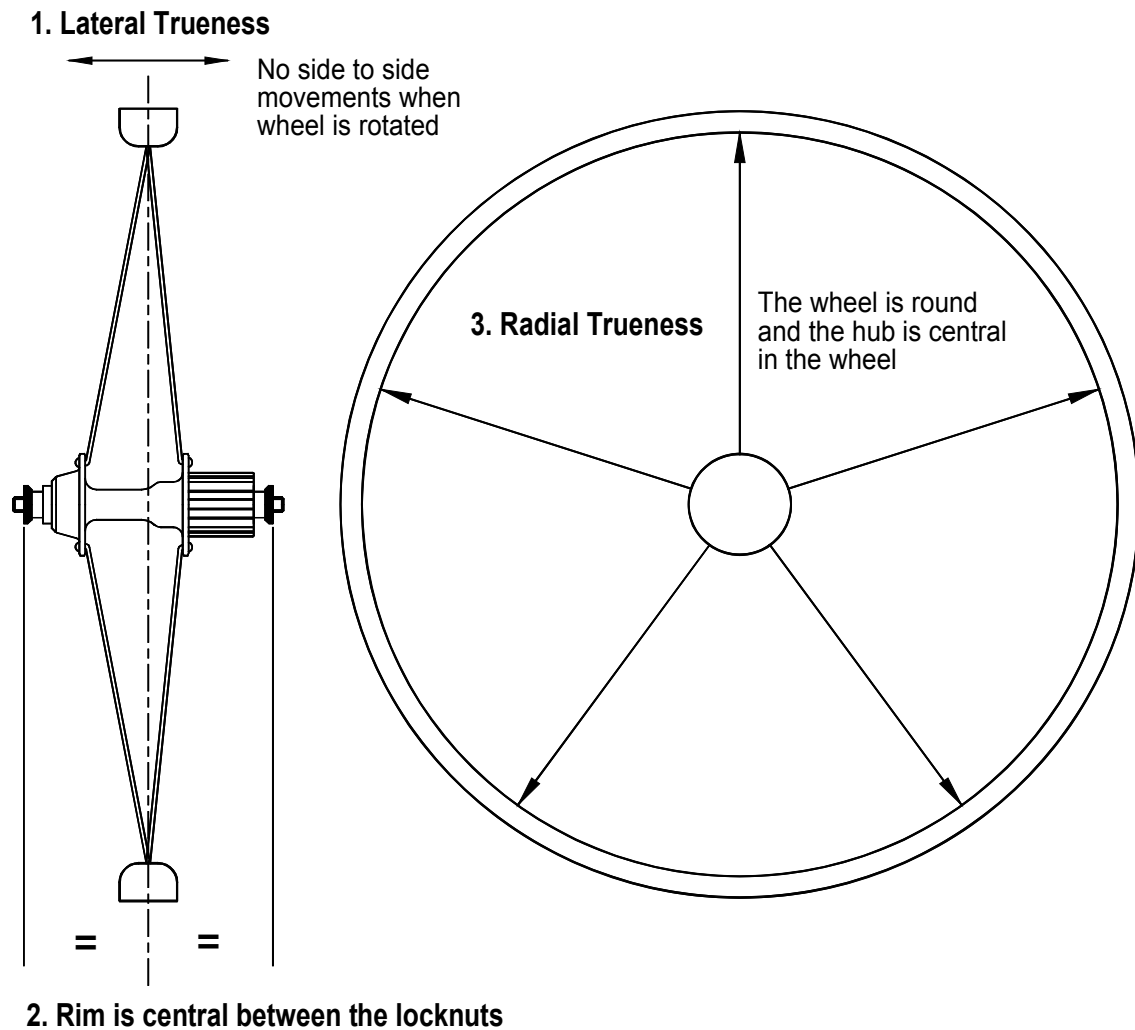


Figure 10 A "True" wheel

## Wheel dish

Wheels are built central between the hub locknuts and **not** central between the hub flanges (see Figure 10). This ensures that the rim aligns correctly with other components of the bike such as the frame, rim brakes and mudguards. If the wheel is not built central then it will be noticeable when swapping different wheels in the frame since you will be continually readjusting the position of the brakes (for bikes that use rim brakes).

Wheel dish is apparent on rear hubs that take a freewheel (a rear wheel is shown in Figure 10) where the flange on the freewheel side is moved over towards the left to make room for the sprockets. Wheel dish describes this non symmetrical state.

The front hub is symmetrical by design and so produces a dishless wheel. The exception being front hubs that take a disc brake where these wheels build with a little dish to accommodate the disc rotor.

The feature associated with dish is the reduced spoke tension in the non drive spokes (and non disc side) and on wheels with extreme dish there may be insufficient tension to prevent the nipples from unscrewing, and the more dish there is, the weaker the wheel.

The hub design dictates the amount of dish and you will find more dish on a 130mm road wheel than a 135mm mountain bike wheel. There's not a lot you can do about dish, your job is to build the rim central between the locknuts and accept the resulting dish. The hub manufacturer has designed the hub so that the resulting dish will not effect on the performance of the wheel. Problems will occur if you modify a hub, for example fitting a wider 8/9/10 speed cassette body onto a hub that was originally designed for a narrower 7 speed one This is often contemplated by people with old road bikes using narrower hubs and frames who want to upgrade their gears to the latest sprocket count and still use the narrower hub and frame (it will also require changing the axle spacers). In this example you will be building in extreme dish that will have a detrimental effect on the reliability of the wheel. I do not recommend modifying the hub and its axle spacing (and by association its geometry) in any way.

A technique to reduce dish is to use a rim that has asymmetrically drilled spoke holes where the holes are positioned more towards the non drive side (front non disc side). This effectively reduces the steepness of the angle the spokes take from hub to rim. They are not common but do exist, however there is nothing wrong with the normal rims and if there were a problem we'd all know about it by now.

## Dishless frames and wheels

Dishless frames are very uncommon but do exist where the frame manufacturer has produced a non standard rear geometry that requires a dishless wheel, i.e. the wheel is built central between the hub flanges. This type of design helps make a stronger rear wheel and crops up on a few (usually very expensive) downhill race bikes. The documentation provided by the frame manufacturer will expressly say "dishless design". The dishless wheel is just as easy to build.

There's a problem where the manufacturer decides to produce a semi-dishless design where they specify the amount of dish required in the wheel. After much head scratching and even with the most careful of planning you only ever know you have it right once you place the wheel in the frame and the wheel ends up in the right place i.e. sitting plumb in the centre of the bike. Thankfully they are rare but I've done a few due to my involvement in downhill racing.

## 3. Tools

Specialised tools and jigs are by no means compulsory but will certainly make things easier. Fortunately they are few in number so it is worthwhile obtaining them particularly if you are building complete wheels. Professional wheel builders are **not** equipped with obscure or exotic tools that make wheel building a simple task and many that I know (myself included) are equipped an extremely basic no frills toolset comprising those listed below. The tools are not complicated and descriptions are given for making most of them yourself. As you will see, I made quite a few of my own, not as a cost cutting exercise but because it was just a natural thing for me to do and I'm sure you have often said yourself "*well, I could make one of them*".

### Spoke wrench

Spoke wrenches come in various sizes so make sure yours is correct for the nipples you are using. The *across the flats* dimension of the nipple is the critical dimension and the wrench must be a good fit to avoid rounding the corners of the nipple as it tightens. There are essentially two standard sizes, those for European/USA nipples (Sapim, DT, ACI etc) and those for the slightly larger nipples found on Far Eastern wheels.

Many designs for spoke wrench exist and it comes down to personal preference. Since they are relatively cheap it is advisable to have at least two wrenches because, being small, they are often misplaced at the most inconvenient time. I even have a red Spokey on my key ring.

I always use the standard Spokey wrench, the red one for Euro/US nipples and occasionally the yellow one when someone brings me a wheel that uses the Far Eastern variety of nipples. Spokey also make a "Pro" version but I never tried one, I guess that makes me an amateur!

For new builders the biggest mistake is turning the wrench the wrong way. One trick I did with my wheelbuilding students was to use a marker pen and place a black mark on one of the wings of the Spokey (see the photograph) such that pressing the mark is the direction for tightening the nipple.



*Figure 11 The Spokey*

## The wheel jig

The purpose of the jig is to support the wheel and allow it to rotate relative to two fixed reference points, one to check for lateral trueness, and one for radial trueness (refer to Figure 10 for a definition of trueness). A wheel jig will become a necessity if you do a lot of work with wheels. For the occasional wheel, whether building or truing, an upturned bike is adequate but oily chains and the lack of stability is a nuisance so it is better to equip yourself with a proper jig.

Jigs can be purchased but the good ones will be very expensive. I was a professional wheelbuilder, I could buy *any* wheel jig I wanted regardless of price. If there were something that would make my life easier and make building wheels easier and more quickly then I would have bought it, however, having looked at what was available I made my own wheel jig.

If you do decide to purchase a wheel jig then that's fine by me because I'd say in the professional world the vast majority of mechanics will be using the high-end jigs and lots of builders will still be using very old cast iron jigs that are no longer available. I take your point that it does seem quite awkward that you need to build a jig in order to build a wheel but I'm sure you want to know exactly what I use. One thing's for sure, a good wheelbuilder will be able to build a wheel using whatever jig is available to them, from the very basic jig to the very complex.

In my amateur days the sole purpose of wheelbuilding was to make the occasional reliable wheel for myself. The first wheels were built using the bike as the jig, which was okay since you only build a wheel every now and again (good wheels last a long time). Once I started building wheels more regularly a better jig was required. I now had a cyclo cross bike that I took off road on some rough rocky trails and the skinny 700c rims took a beating and needed replacing more frequently (rims were cheap and like tyres I regarded them as consumables).

It never crossed my mind to buy a wheel jig for these few wheels so I designed my own that bore little resemblance to anything in the shops. Wood was the material of choice because it makes a very solid, rigid jig and wood is easy to get hold of, and easy to work with.

The drawing in Figure 12 shows the key dimensions of my wooden jig that is suitable for everything from road through to BMX wheels.

I made mine from 20mm thick MDF (Medium Density Fibreboard) although I'm sure other types of wood/material will be just as suitable. When screwed together it will produce a very strong and rigid jig. One support leg is firmly attached to one side; the other support is adjustable for different hub widths by cutting two slots in the base board allowing it to slide on the securing bolts. The jaws that supports the wheel are made from steel (about 6mm thickness is ideal) with suitable cut outs to take the rear hub axle since it is usually a larger diameter than the front axle. The wheel is secured in the jig using the hub skewers. There are no built in trueness checking gauges, instead a broad flat base is used onto which are placed separate gauges.

Painting the jig white makes for a clear bright working zone and gives excellent contrast when used in conjunction with the black reference plate of the separate gauges.

*This jig is superb and is the one I used for all my amateur days and for the first couple of years as a professional builder. I looked at others and one way or the other tried most of the high-end jigs but always returned to my wooden one. When I ran wheelbuilding courses this exact design was used by the wheelbuilding students. When the wheelbuilding courses eventually finished, the final students purchased them without hesitation.*

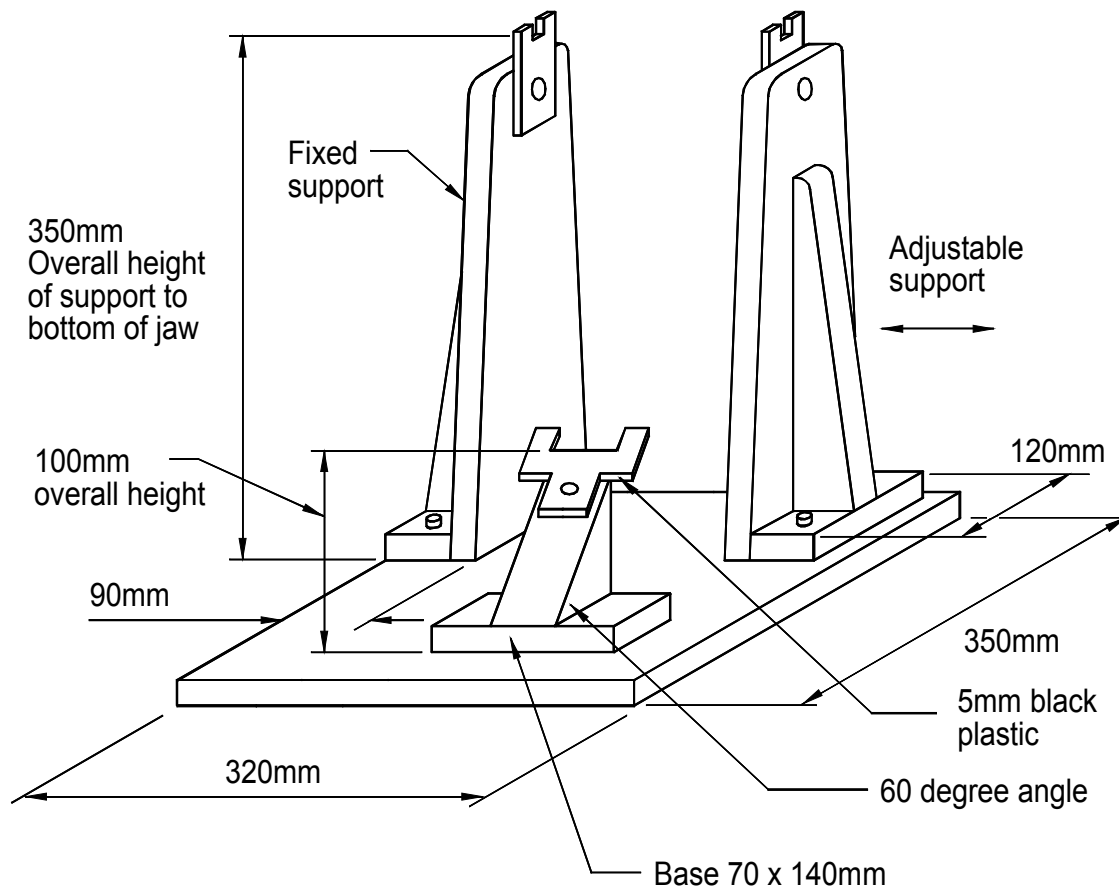


Figure 12 The wooden jig plans

You will require two reference points for lateral and radial truing, there are many options and there is plenty of scope for experimenting to find the best method for your own needs. I use a simple pedestal as shown in the example although the forked profile has changed very slightly from the one shown above (see the photograph in Figure 13)

Make the pedestal with a broad flat base letting it rest on the jig surface and slide it over the base to achieve sideways and height positioning. The weight of the pedestal is sufficient to keep it in place and this is helped by using a non-slip material on the underside. It is extremely easy and fast to use and does not require the time consuming process of twiddling knobs and dials and positioning sliders which are typically found on the shop-bought jigs.

Later I designed a better method for checking radial trueness which is described on page 24.

Shown here is my wooden jig made from white laminated MDF.

It's a very rigid jig and there's no flex.

In the photograph note the modified reference plate on the pedestal that is different to the one in the above diagram. The gauge is shown checking lateral trueness. I always make checks from this side so there is no need to have a similar profile on the other side. Instead, on that side I have a protruding reference that I use to check lateral trueness when a tyre is on the rim (the shape becomes more obvious when you try it yourself when you check a wheel with a tyre on).

The gauge shown is **only used** to check lateral trueness. The gauge to check radial trueness is shown on page 24)

The jig is seen here with a 700c road wheel in it. If I were to replace it with a smaller diameter mountain bike wheel then all I need to do is move the gauge a fraction forward making it very fast to use when dealing with lots of different size wheels with and without tyres on. Just pop the wheel in and position the reference – easy.



Figure 13 The wooden jig

Here you can see the adjustable leg of the jig that accommodates different hub widths. The leg slides against a guide block that has preset marks for the different hub widths.

It is shown in the 100mm position for a front hub. The settings relate to the hub width across the locknuts where the common settings are:

100 – Front hubs

127 – Old style road hubs (7 speed)

130 – Road hubs (8,9,10 speed)

135 – Mountain bike hubs



Figure 14 Hub width adjustment

If you only build standard quick release wheels then there's no need to go any further with your wooden jig but if you use hubs other than quick release then something else may be required.

Mountain bikes were evolving fast and the hubs used were moving away from standard quick release to something more exotic starting with 20mm bolt through front hubs. These 20mm hubs can be accommodated in the wooden jig using end piece adapters in conjunction with the quick release.

These adapters drop into the ends of the 20mm front hub and a quick release skewer goes through the middle. The smaller diameter **must** be long enough so that it locates on the hub bearing and not just resting on the hub end spacers.



*Figure 15 20mm jig adapters*

They are not easy to make yourself but I'm certain something similar can be purchased because locating 20mm hubs in wheel jigs is a common operation.

They are also used in Jig Mark 2 but without the need for a skewer.

Then came 12mm and 15mm bolt through *rear* hubs and the wooden jig could not cope. The way forward was to have a jig that used screws to grip the hub. Due to the requirement for screws and because of the different forces involved it had to be made from metal. In principle it is exactly the same as the wooden jig with only the hub securing method different. I called in a few favours from my mates who still worked in engineering and Jig Mark 2 was created – the ultimate jig!

## **The metal jig**

This is what I currently use and I can't see it being improved in any way. It's my perfect jig because it can accommodate all types of hub yet in all other respects is the same as the wooden jig. I see other jigs out there full of knobs, dials and levers and I've even tried them but this is the one for me.

I didn't make it myself I just sketched out the design. I was fortunate to know someone who worked in engineering who made the screw threads and the threaded top collars, and someone else who worked as a blacksmith specialising in wrought iron gates who welded it all together. Thanks guys.

Here is my metal jig looking from the working side. Only the method of holding the hub has changed and all other aspects remain the same as the wooden jig, i.e. painted white and with a broad flat base onto which are placed two measuring gauges for checking lateral and radial trueness.

It features two screws although I do not use the left side screw and it is locked in position with a locknut. The ends of the screws are dimpled to locate the hub axle.

I am not providing a detailed drawing but if you want to make something similar then the key dimensions are:

Width between uprights : 200mm

Height from thread centreline to surface of base : 350mm.

Screws : M18 with the ends dimpled using a standard drill.

Uprights : 40mm box section.



*Figure 16 The metal jig*

This photograph shows how the jig evolved.

The first attempt was to have the two uprights welded on to a small plate that was in turn bolted onto a wooden base board.

Due to the forces involved the legs just splayed outwards when the hub was gripped because the metal baseplate just bowed.

So I welded the baseplate onto a 50mm section and added some feet to rest the wooden board on. This was good and worked well but there was still very *slight* bit of flex so I added the 4 webs to make a very solid jig.

It's got nothing to do with Mavic. I just put the sticker on.



*Figure 17 Nothing lightweight here!*

## Holding 12mm rear hubs

12mm (and 15mm) hubs are commonly found in the rear wheels of downhill bikes and were the reason why the metal jig had to be designed.

This type of hub has a hollow axle and is bolted into the bike frame with a long bolt and holding these hubs in the wooden jig was not possible.

Shown here is a 12mm rear hub looking on the non drive side.



Figure 18 A 12mm rear hub

The hub is held in the jig with a pair of 5/8" steel balls either side of the hub.

The screws of the jig are dimpled and the balls are held in place using "Blu-tac" (also known as *poster putty*) so that when you take the wheel out, for example to check dish, the balls remain in place.

The balls remain stationary with the hub rotating on its own axle and bearings.

It looks crooked in the photo but that's due to the camera angle and also the tapered profile of the Chris King hub body. It is perfectly square and in line with the hub axle.

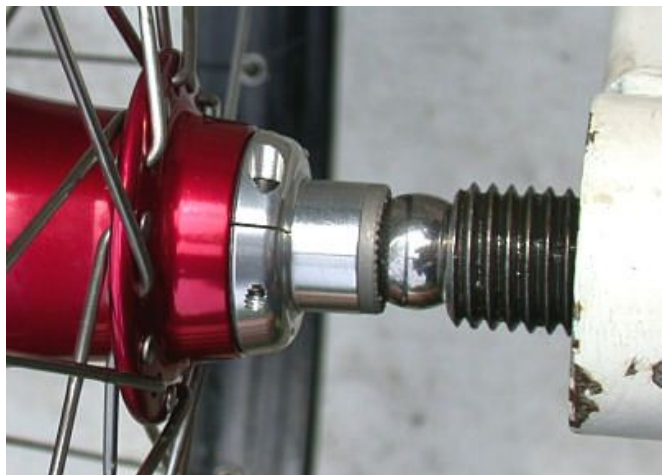


Figure 19 Holding a 12mm hub

Note : do not adapt this technique for 20mm front hubs because the balls will not locate on the hub axle. Use the adapters as previously shown.

## Checking radial trueness

This is the very unique gauge I devised for checking radial trueness. It is extremely easy and fast to use and I couldn't imagine not using one. It certainly beats all the other high-tech devices found on shop-bought jigs.

Note, I always use separate gauges for checking lateral and radial trueness, i.e check and adjust in one direction, then swap over gauges and check the other.

The dimensions are shown on the next page.



This is the side-on view with the gauge in place. You **do not** check radial trueness from this view. The same gauge is used for all wheel sizes.



You are now stood upright with no stooping looking straight down at a slight angle. As you rotate the wheel the radial trueness is easy to see as gaps of light are seen expanding and contracting. Once you get used to it, it's unbeatable.

*Figure 20 Checking radial trueness*

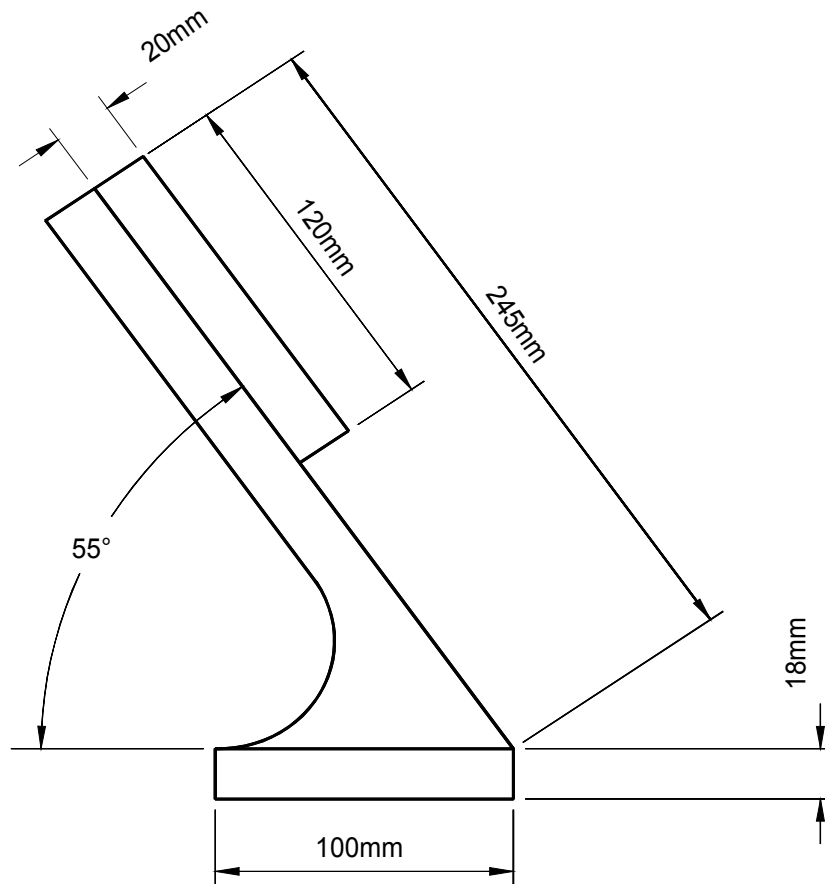


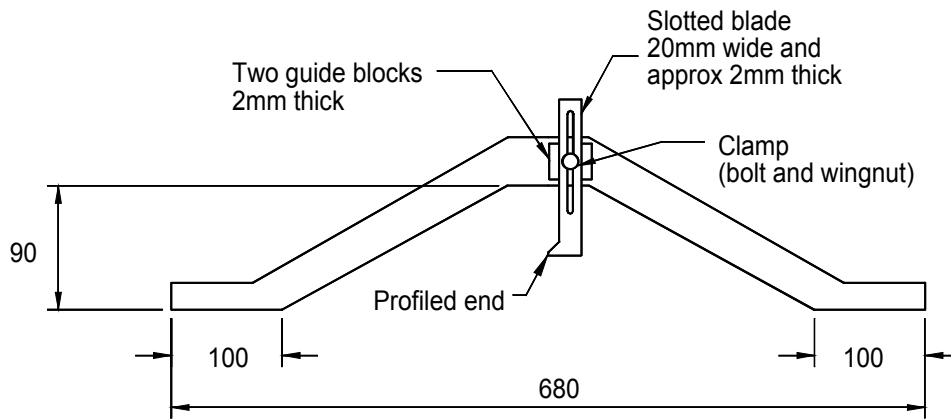
Figure 21 Radial truing gauge

## Wheel dishing gauge

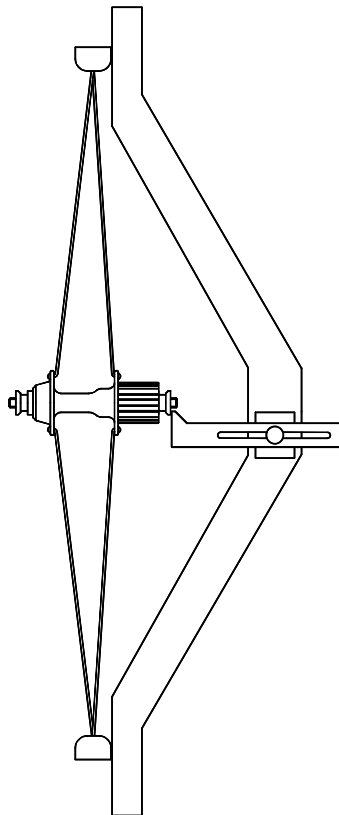
The easiest way to check that the rim is central between the locknuts is to use a gauge as shown in Figure 22. The gauge is placed on one side of the wheel and the indicator positioned so that it just touches the outer edge of the hub locknut (Figure 23), it is then placed on the other side of the wheel and the indicator should reach the same position relative to the other locknut if the rim is central. If you were building a dishless rear wheel then place the indicator on the outside of the hub flange. The wheel dish should only be checked when the wheel is reasonably true laterally.

Some wheel jigs incorporate a mechanism that automatically checks the dish as you build the wheel. Even if you have one of these jigs you should always check the dish with a separate tool because it's more accurate.

The design of a dishing gauge is simple and is easy to make using the same 20mm wood as used for the jig with the key dimensions shown below.

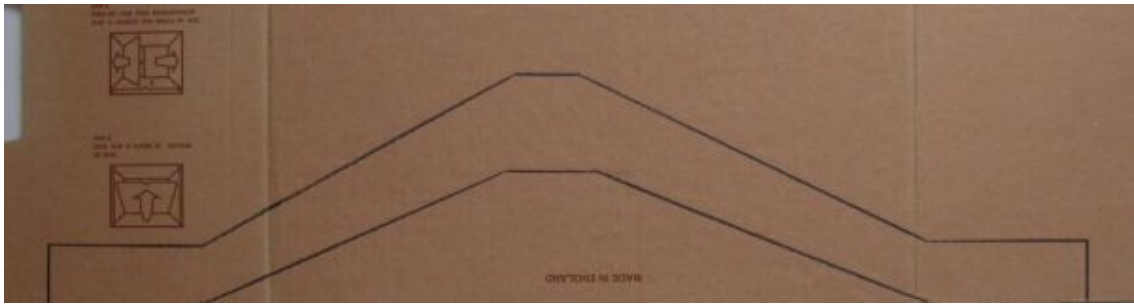


*Figure 22 The wheel dishing gauge*



*Figure 23 Using the wheel dishing gauge*

If you only do a few wheels then quickly cut an entire gauge from stiff corrugated card and hold something thin against it with your thumb to act as the indicator, you can easily hold the grip as you transfer the gauge to the opposite side of the wheel. In the photo (next page) I've used a 6" steel rule but I'm not measuring anything, just comparing each side.



Make from an old cardboard box.



*Figure 24 Cardboard dishing tool*

... and it costs nothing, and it works extremely well.

I actually use a dishing gauge that I purchased because I thought the Park Tools gauge (code WAG-1) was perfect and could not be improved. August 2005 - looking on the Park Tools website ([www.parktool.com](http://www.parktool.com)) it would appear that it's now unavailable and not listed in their product index which is a shame. The latest one is the WAG-3 and looks very similar to the home made one I described above. So without access to a WAG-1 I would no doubt be making my own tool and then try the WAG-3 to see if it were any better. By *better* I mean faster/easier to use – remember I have commercial considerations and do lots of wheels so your decision making process will be different. I think you'll find the cardboard gauge works extremely well.

One well used WAG-1.

It featured a spring-loaded pointer that was easily adjustable with one hand.

The spring on mine snapped so I drilled out the pivot and made a new spring out of a spoke (DT Revolution if you really want to know). I replaced the old pivot with a nut and bolt.

I never use the knurled locking collar.

I also repositioned one of the plastic feet (not shown) that rest on the rim because the original spacing was too far apart.



*Figure 25 The WAG-1*

## **The nipple driver**

Using a nipple driver makes building the wheel easier and faster.

The nipple driver is an indispensable tool and I never build a wheel without it. The blade of the nipple driver is placed in the slot in the nipple and briskly rotated via the action of the cranked shaft. As you turn the nipple the top of the spoke releases the blade and the blade spins freely with no further turning of the nipple. Using this tool is highly recommended because it allows you to quickly screw all the nipples down to the same thread engagement making the wheel virtually true radially (i.e. round) with little thought and no effort.

The nipple driver is a simple tool to make and a drawing is shown in Figure 26. Make the cranked blade from an old screw driver blade. A good idea is to purchase a cheap screwdriver because the softer material will be easier to bend, don't get a high quality screw driver because you will not be able to file or bend it. File the end profile and bend it in two places to form the cranked shape as shown. Purchase a standard file handle available from any good hardware shop or engineering supplier and drill it out so that the blade is inserted with a loose fit and spins freely.

There is no need to provide an elaborate method for securing the blade in the handle, you hold both handle and blade with one hand when locating the tool then the pressure exerted whilst turning keeps it firmly in place. The procedure becomes intuitive and fast after a short time. If you are struggling to see how this tool works then make one and try it out.

You can buy these tools but they are not that good. They may look nice and high tech but they just don't work as well as the one described here.

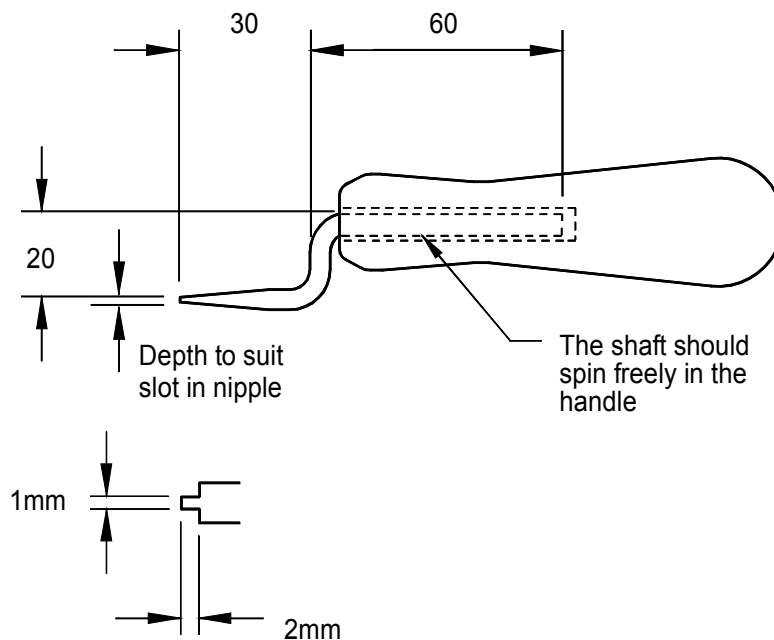


Figure 26 The nipple driver dimensions

You may wish to alter the end profile to suit your own preferences i.e. a longer point (greater than 2mm) will not tighten the nipple as much, a shorter one will provide more tightening. Alternatively you can make a set of blades since they are easily interchangeable in the tool handle.

Some wheelbuilders use a power drill with a straight bit (as opposed to cranked) using the same end profile as shown for the nipple driver but I never use a power drill and always use the nipple driver as shown here. The hand tool gives me more control and gives better feedback on how the nipple is tightening, plus I find it just as fast as the power drill and it never lets me down when doing race service out in a field.



*Figure 27 The nipple driver*

## Leather gloves

You'll need a pair of leather gloves in the latter stages of wheelbuilding where you need to grasp and squeeze the spokes (I'll explain why in the building section).

The gloves need to be substantial and the best ones I found were from gardening shops called *heavy duty pruning gloves* – the ones for pruning prickly bushes. They are made from canvass and reinforced on the palms and fingers with thick leather and surprisingly they are very cheap.

Here you see one of mine, note the markings across the palm and fingers made from the spokes.



*Figure 28 Gloves*

## CX-Ray tool

The Sapim CX-Ray spoke is a very thin bladed spoke with a cross section of 2.3mm x 0.9mm and when building they twist very easily making tensioning them difficult. Sapim supply their own tool for holding the spoke in place while tensioning but I found it awkward to use so I made my own. It's a tricky one to make and I am only describing it here since it's a tool I regularly use. If you do not use CX Ray spokes then forget about this. The cross sectional profile is shown in Figure 29, with a depth of 50mm. I used a piece of 0.9mm feeler gauge (actually two at 0.45mm each) that was sandwiched between two pieces of aluminium plate. Initially it was bonded together using a high strength industrial adhesive but the joint failed after a few months so a friend who works in the aerospace industry took it away and had it riveted together. The stepped design is important because it makes locating the tool on the spoke very easy.

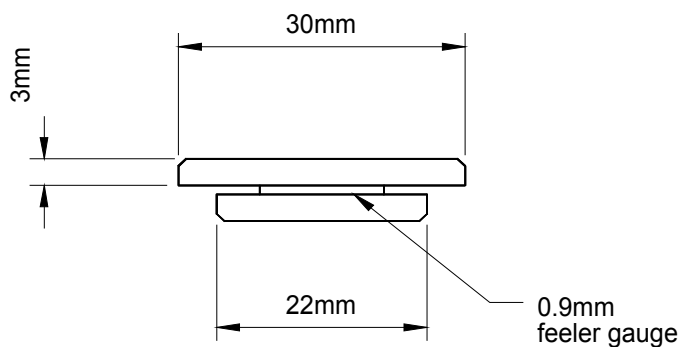
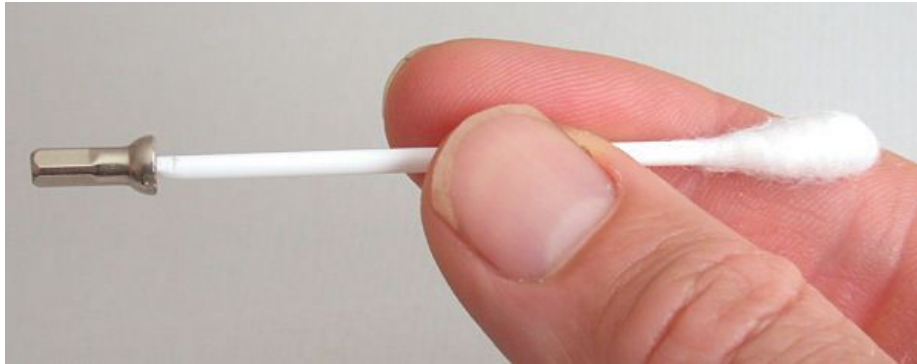


Figure 29 The CX Ray tool (cross section shown on the left)

## Nipple holder

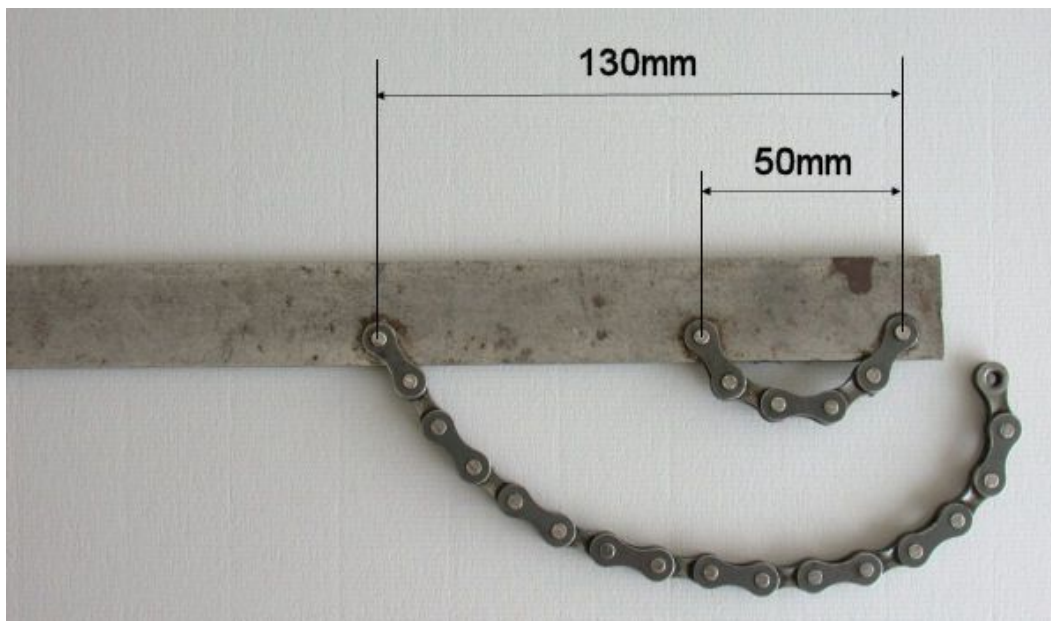
If you look on the websites of Sapim and DT you will see that they supply a small tool called a nipple holder to help placing the nipples into deeper section rims. I tried one but found it cumbersome and preferred to slice the plastic portion of a cotton bud at an angle. Push it into the slotted end of the nipple and you can easily place the nipple into the rim and start the thread engagement by twisting the bud.



*Figure 30 Nipple holder*

## Chain whip

Although not a wheelbuilding tool a chain whip is a tool I use often when removing rear cassette sprockets. I made my own out of a piece of 3mm x 25mm steel with an overall length of 300mm plus a piece of old chain.



*Figure 31 The chain whip*

## That's all

As far as wheelbuilding goes the tools described here are all you need and you can easily build wheels with far less. If you ever see me at a race you will see that I have a rather large array of tools but apart from the ones shown here the rest are all concerned with removing sprockets, dismantling hubs, and a load of tools for sorting out disc brakes.

## 4. Building

This section will show you how to build a rear wheel using 32 spokes arranged 3 cross. The later comments will show how to adapt this procedure for many other standard wheels however this configuration accounts for 90% of all the wheels I build.

Your BIG advantage over the commercial wheel builder is that you have no time constraints so use your time to make a good job of the wheel. Never race against the clock to see how fast you can build a wheel because the quality will surely suffer.

### Lubricants and Adhesives

Many of the spoke manufactures are advising the use of adhesive or other spoke preparations on the spoke threads to prevent the nipples coming loose and some manufacturers go further and make special self-locking nipples which prevents them unscrewing, whereas many wheel builders (myself included) take the opposite view and use oil.

The purpose of the oil is to reduce friction and allow the nipple to be tightened to achieve the correct tension in the spoke; the oil will not subsequently cause the nipple to work loose. Correct spoke tension will prevent the nipples working loose but we do not increase the spoke tension just to keep the nipples in place. A key fact to remember is that a tight wheel is a strong wheel and a by-product of this tension is that the nipples stay in place making it reliable as well as strong.

Components assembled completely dry will be difficult to bring to the correct tension, the wrench will be hard to turn and be accompanied by screeching sounds and in severe conditions you will shear the nipple or damage it so that it could later fail when the wheel is used.

The oil I use is standard motor engine oil.

Don't use any vegetable based oils or other fats because although they allow the wheel to be built up the oil/fat will decompose over time and your nipples are likely to get stuck which makes re-truing difficult.

I am not opposed to using adhesives, I do not recommend them because it encourages sloppy building and low tensioned wheels relying on the adhesive to *try* and sort out any potential problems. If you run out of your favourite *glue* you will have no confidence to build without it and the job stops.

Okay, I'll own up. On my shelf is a bottle of *Loctite 222* threadlock adhesive, which is a low strength, standard engineering product for securing threaded fasteners. It has lubricating properties so achieving correct spoke tension is easy and also it's a non permanent adhesive which means you can still adjust the nipples if the wheel requires truing at a later date and even if the bond is broken the product will continue to do its job keeping the nipple secure. For more information go to [www.loctite.com](http://www.loctite.com) and do a product data sheet search on 222. I often used this product on mountain bike wheels because these wheels take a few knocks and a local flat spot in the rim could cause a loss of tension in the spoke and a chance for the nipple to unscrew, and then the neighbouring spokes would lose tension leading to a generally loose and unsound

wheel. The threadlock kept things in place and ensured the wheel stayed relatively sound. I never went to races outside of the UK so I knew my team issue downhill race wheels would be okay when they went on a foreign jaunt until the next time I had a chance to look over them and sort out any wheel related problems.

My own wheels are built with oil but customer mountain bike wheels tend to get a bit of 222 to ensure they keep going for as long as possible (you do not have to deal with customers).

For **your wheels** (including mountain bike) you will be using oil because you will be continually monitoring your wheels and be fixing any problems before they become serious. Chances are you will never have to touch them. Mountain bikers reading this already know that fixing wheels is part of the game, but a good strong wheel built using oil will sort out most things (especially if you are accustomed to the loose shop bought variety).

I'll show you where to put the oil next (and adhesive if you really must).

If you decide to use adhesive then don't apply it just yet. It gets applied during the build process and I'll tell you when to do it. You should **not** apply any oil to spokes that will have adhesive applied, but you should oil the rim as discussed later.

My technique for applying the adhesive relates to *Loctite 222*. Spoke manufacturers may produce their own adhesive in which case follow their instructions.

## Determine your spoke lengths

Determine the correct length spokes (see *Spoke Lengths* page 76). This is an **important** part of the wheel building process because the correct length spokes will make building the wheel much easier. It is harder to build a wheel using short spokes because you will be struggling with tight spokes too early in the building process. You can get away with spokes that are too long but in the finished wheel they must not protrude more than 2mm above the top surface of the nipple, plus the wheel takes longer to build.

Our rear wheel will require two lengths; the drive side spokes typically 1 or 2mm shorter (the geometry of some disc brake rear hubs results in the same spoke length either side but the text here assumes 2 different lengths). Take 16 of each and clearly segregate them, preferably into two containers, one marked **Drive** the other **Non drive**. Alternatively place them on well separated sheets of paper marked drive and non drive. If you accidentally mix these up or choose a spoke from the wrong pile during the lacing process you will encounter major problems that will only surface much later on in the build process in which case it is often quicker to disassemble and start again rather than try and find the problem spokes.

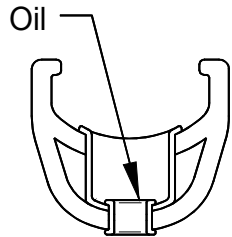
## Measure your rim

If you haven't already done this while determining your spoke lengths then do it now. I'll not explain why it's necessary here but you'll be glad that you did measure it – maybe not now but certainly in the future. Please see measuring rim diameters on page 83. Measure it and write it down somewhere safe.

## Apply any rim stickers

Stickers are optional, I always use the spoke manufactures sticker that is included in the box of spokes. If you want to apply stickers then do it now while your hands and the rim are clean otherwise if you contaminate the rim surface with oil they will not stick as well.

## Oil the rim eyelets



**Always** lubricate the inside of the eyelets on all rims, those with eyelets and those with no eyelets. This need only be a light wipe with a cotton bud with a little oil on it.

If you do not oil the rim you will never be able to tighten the nipples sufficiently due to the high friction at the nipple/rim interface.

## Oil the spokes

Pour some of your oil into a container such as the cap off a bottle. Take each bundle of spokes in turn and tap the spoke threads on the bench to get them all level and dip them into the oil about 2mm, then tap them on a rag to remove the excess oil. You just want them *lightly* coating and not swimming in oil which is messy.

If you want to practice lacing up (then dismantling) the wheel a few times then leave the oil off the rim and spokes to keep things clean. Only apply the oil when you aim to complete the wheel.

The above steps were all preparatory and from now on the actual building will start. I always stand up when building a wheel but I know a few people who sit down. I also like the room to be quiet. The choice is yours.

## Lacing the Wheel

Lacing is the task of assembling the spokes in the wheel using the correct pattern and positioning them correctly relative to the valve hole.

Steps 1 - 9 below describes the procedure for lacing a rear wheel using simplified diagrams. A mark ● on the hub centre indicates that you are looking on the drive side (the drive side is the side that takes the sprockets) and all the wheel diagrams are viewed from this side.

After completing each step take a good look at your wheel and relate it to the diagram and understand the logical progression. Make sure it is correct before moving to the next stage, a mistake made early on will cause major problems as you try to complete the latter stages of the lacing process.

If the rim has a manufacturers label then it is good practice to ensure it is readable when looking on the drive side so turn the rim over if necessary when starting step 2.

When lacing, the nipples should only be attached a couple of turns just to hold them on the spokes.

Look at your rim and check if the rim holes are offset (refer to Figure 1 on page 7). If the offset is type 1 or there is no offset then use the lacing procedure as written. If it is the less common type 2 rim then there are just two slight modifications and these are clearly shown in the text. Note, the drawings relate to an offset rim of type 1.

There is a beautiful symmetry about the wheel and you will soon know if you are lacing it wrong because spokes will not go where they ought to and the symmetry of the wheel is lost.

### Step 1

Take 8 drive side spokes and place them through the drive side flange of the hub from the outside using alternate holes. If the hub has alternate countersunk holes then ensure the first spoke is placed so that the elbow rests on the countersunk side.

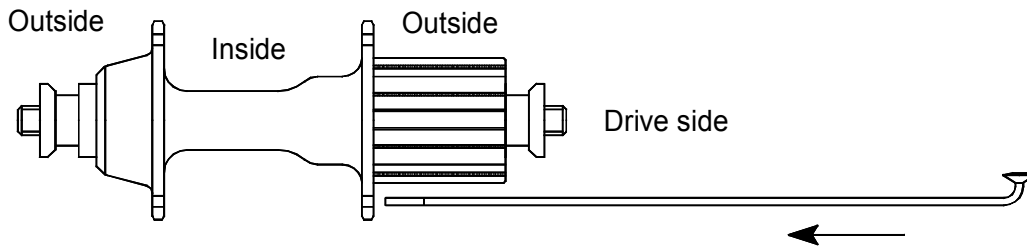
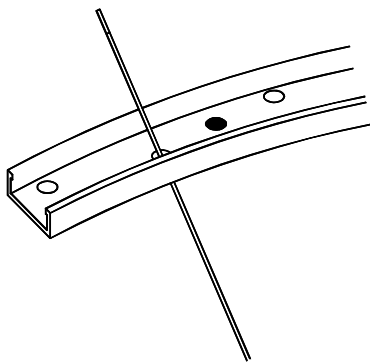


Figure 32 Lacing step 1

### Step 2



Place a spoke through the rim hole to the left of the valve hole (shown here as the black circle) and attach a nipple.

It is important to get this first spoke correct because it determines the placement of all other spokes in the wheel and ensures that the valve hole ends up in the correct position.

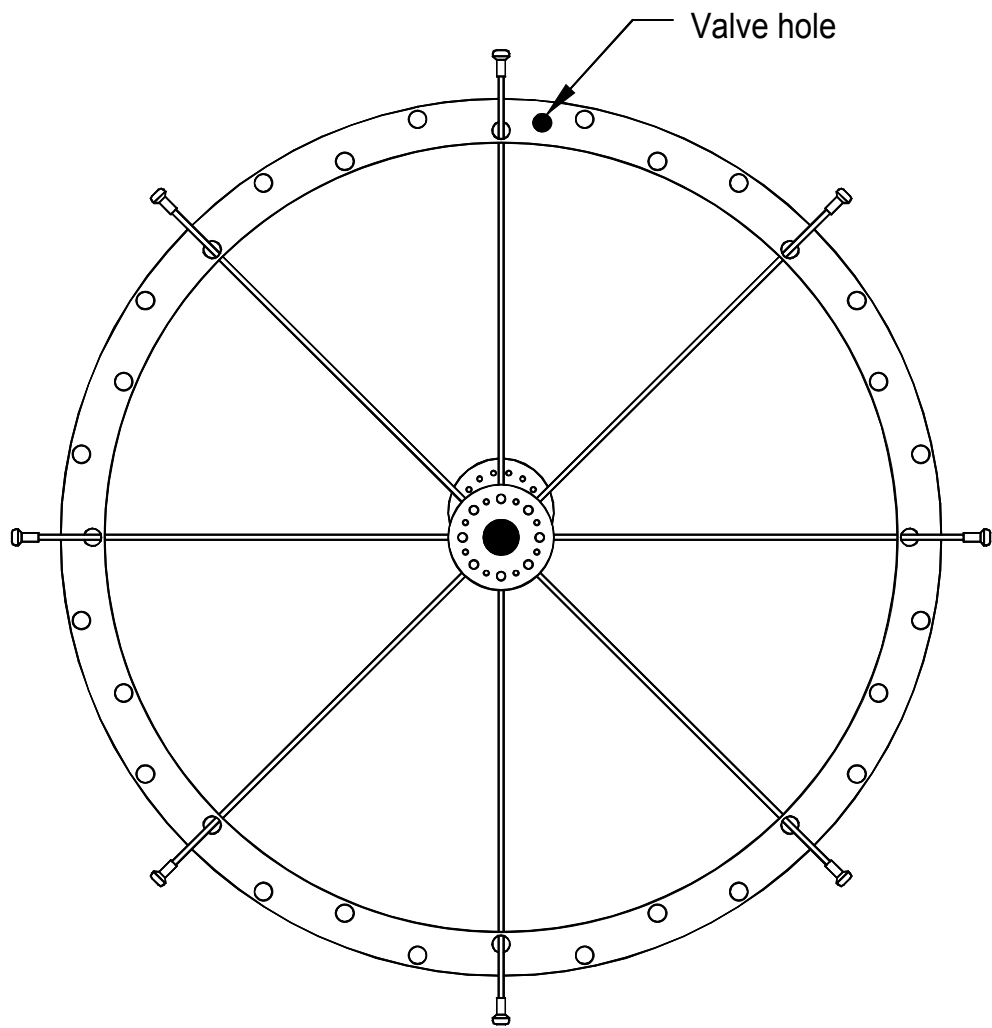
*Type 2 rims (see Figure 1 on page 7), place a spoke through the 2nd left rim hole.*

Figure 33 Lacing step 2

*The following diagrams are drawn semi 3 dimensional. After much thought and evaluating other means of representing the wheel I believe this to be the best method.*

**Step 3**

Place the next 7 spokes in every 4th rim hole.



*Figure 34 Lacing step 3*

## Step 4

Look at a spoke (any spoke will do) on the drive side and note the hole where it passes through the hub. Using this hole sight across the hub and notice how the holes on the opposite flange are offset slightly, there is one hole either side.

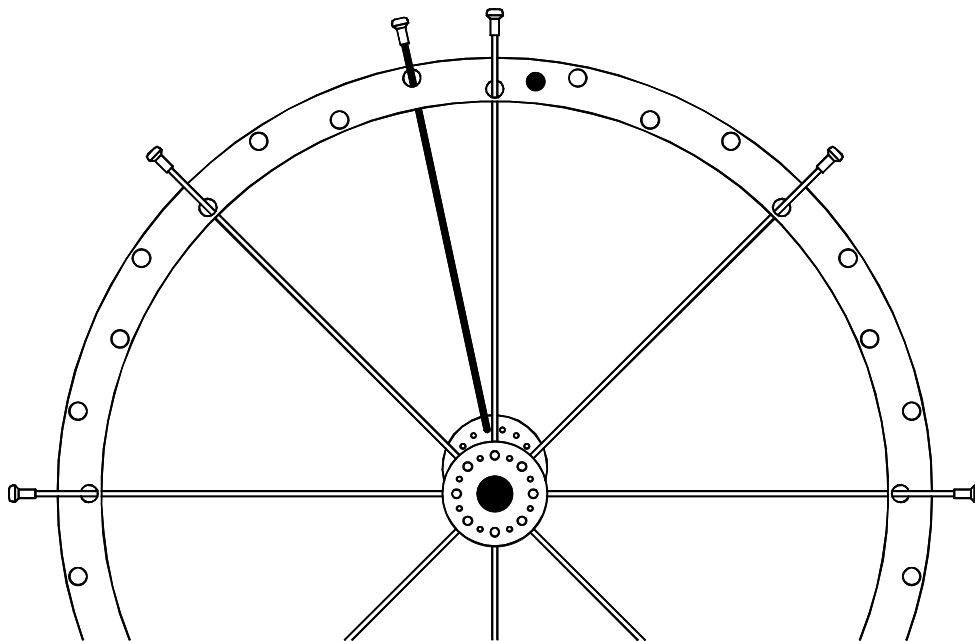
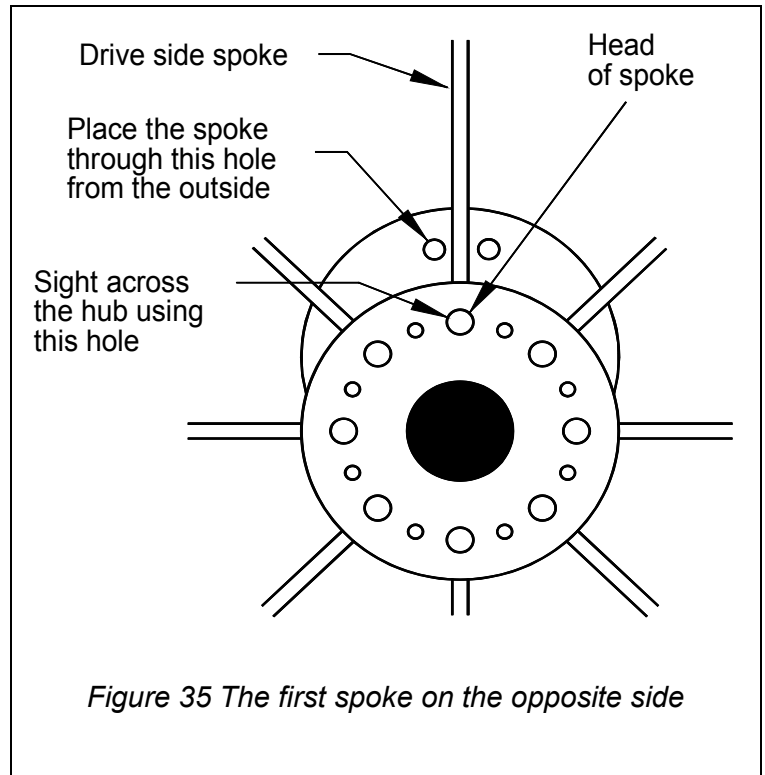
Select the hole to the left.

Take a spoke from your box marked **Non drive** and pass it through this hole from the outside.

*[Type 2 rims, select the hole to the right]*

Place this spoke in the rim to the left of the spoke used for sighting purposes and attach a nipple.

*[Type 2 rims, place to the right]*



*Figure 36 Lacing step 4*

## Step 5

Continue on the opposite side with 7 more spokes. There is no need to sight any more, the spokes are placed through alternate holes in the hub and placed in the rim every 4th hole spokes (shown in black in Figure 37). As you become more proficient you can hold the wheel flat looking on the opposite side and drop these 7 spokes in, then place them very quickly adjacent to a drive side spoke. The second set of spokes are now in.

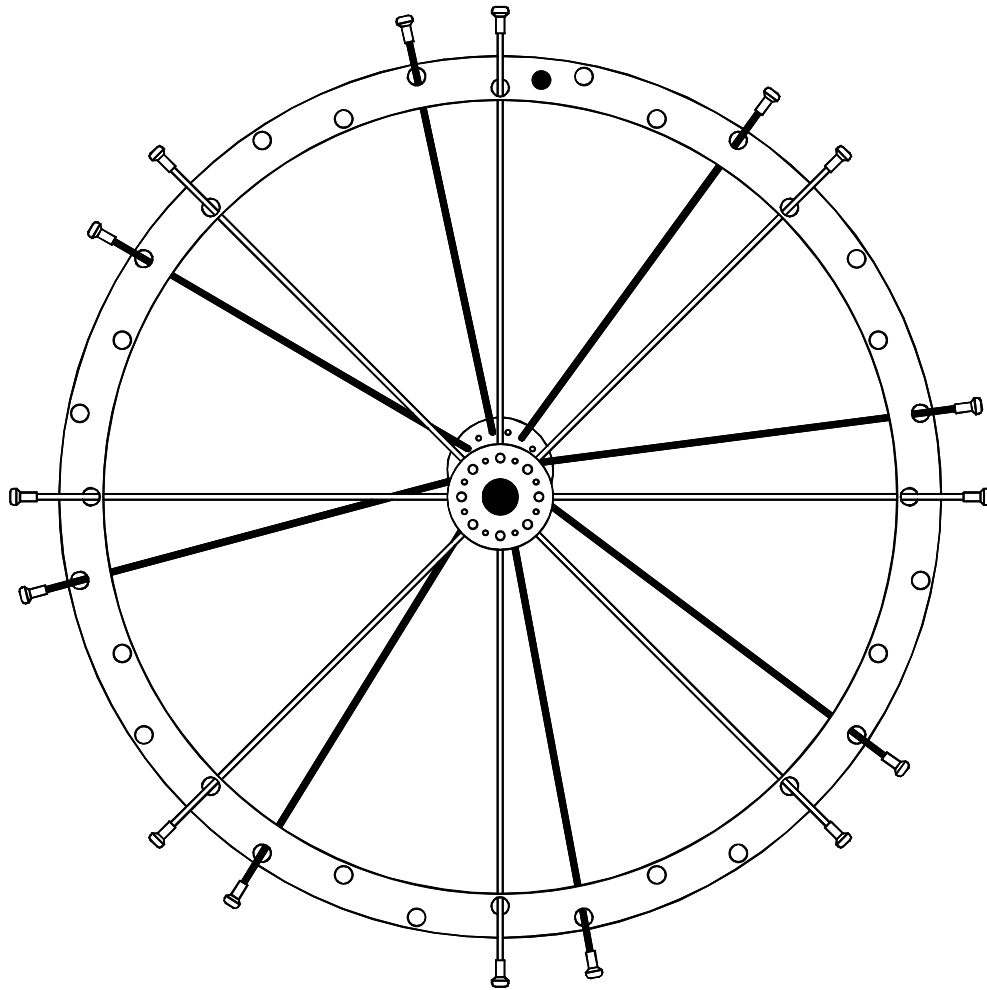


Figure 37 Lacing step 5

The following diagrams now show a more realistic side view of the wheel. For clarity only the spokes in the drive side are shown.

### Step 6

Grip the hub flange and rotate in the direction shown. The two spokes adjacent to the valve hole will slope away from it (note, the diagram only shows the drive side spoke).

If the spokes are a good fit in the hub then it may be difficult to rotate, so support the rim between your legs and use both hands either side to rotate the hub, you may even have to start the spokes moving by pushing each spoke in turn close to the elbow to start them moving tangential. Alternately, the spokes may be relatively free in the hub and it will not hold its rotated position, in which case you will have to carry out this exercise again whilst starting step 7.

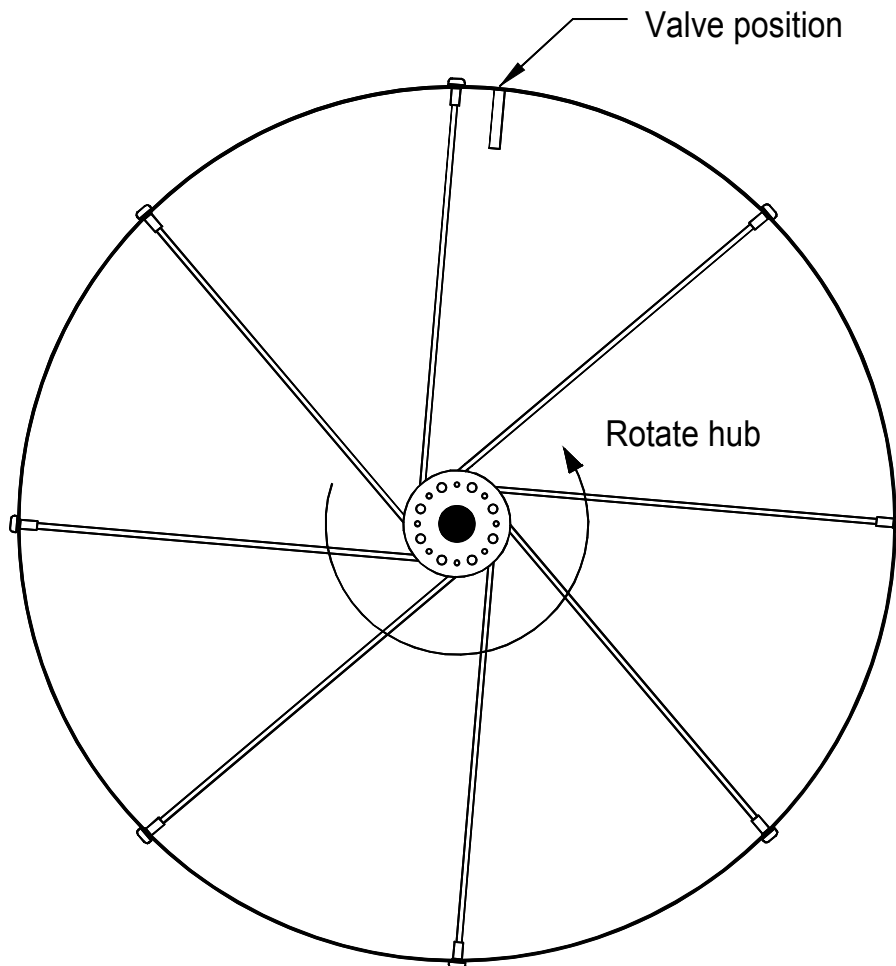


Figure 38 Lacing step 6

## Step 7

Take a drive side spoke and pass it through the hub from the *inside* of the drive side to the outside, any hole will do.

This spoke (shown in black) will radiate back to the rim in the opposite direction to those already placed. Since it is a 3 cross wheel it will cross 3 other spokes before entering the rim (see below).

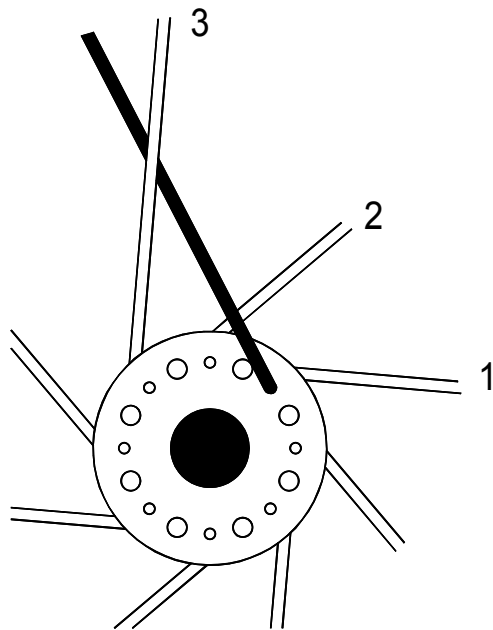


Figure 40

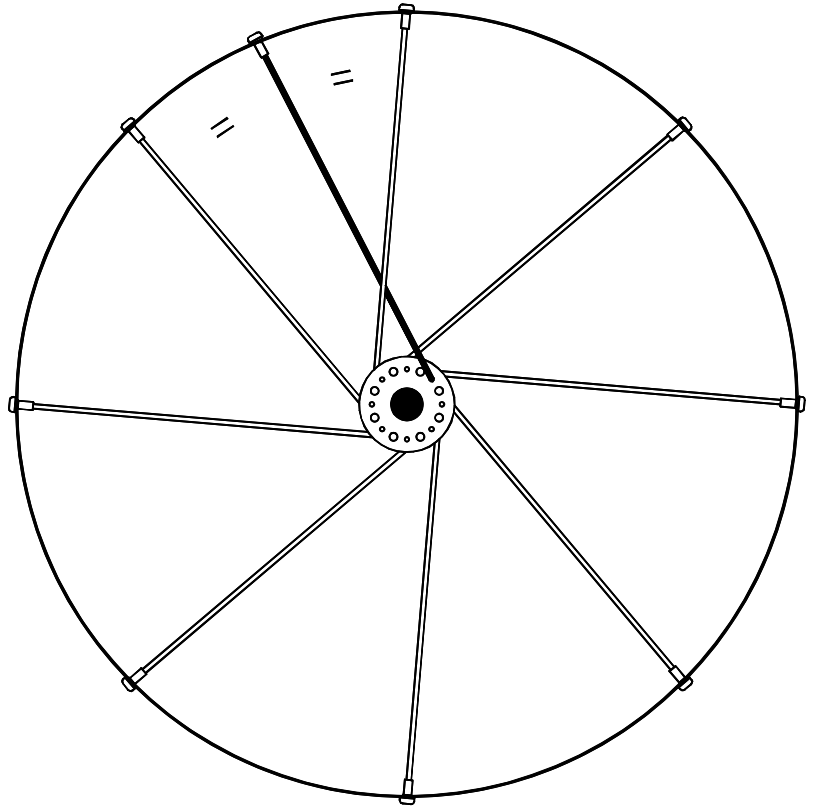


Figure 39 Lacing step 7

Pass the spoke *over* spokes 1 and 2 and weave it *under* spoke 3. In order to weave, the spoke must be flexed very gently, be careful not to kink the spoke or scratch the rim surface with the threaded end of the spoke.

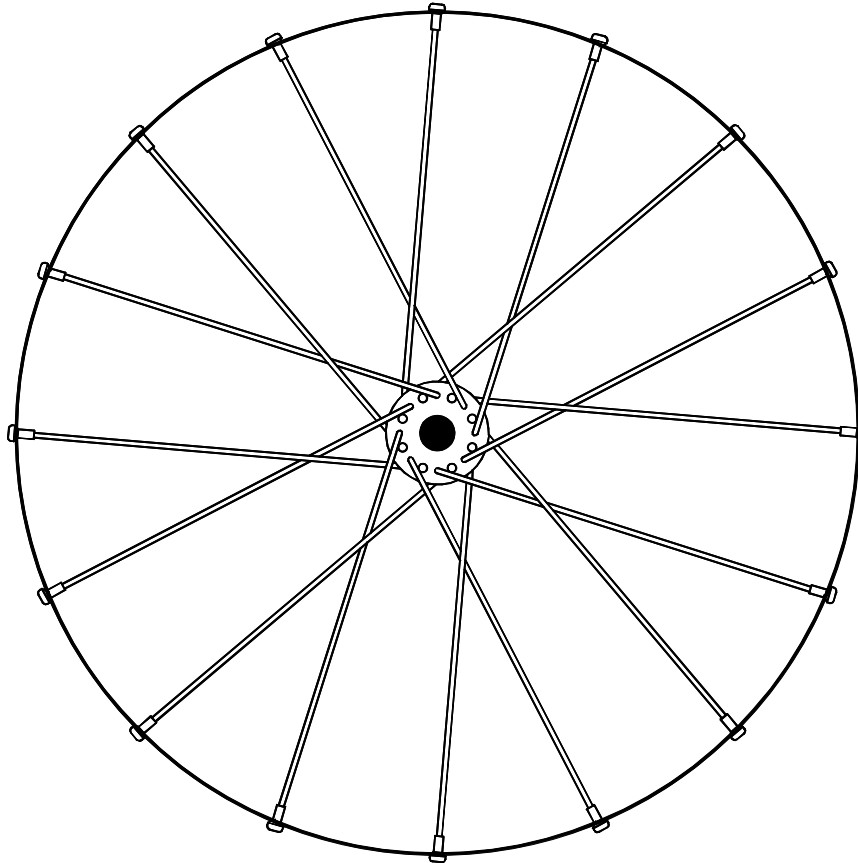
There are two options for placing the spoke in the rim but it must go through the hole that is central between the two other spokes on the same side (see Figure 39).

On some rims it may be necessary to use the nipple driver to attach the nipple. First weave the spoke and position it near the rim hole then place the nipple into the rim and give it a couple of turns with the nipple driver as you bring the spoke towards the nipple.

With deeper section rims that do not have double eyelets be careful not to drop the nipple into the rim box section because it can be awkward to get out. If you have difficulty placing the nipples in this type of rim then use the nipple holder shown on page 31.

## Step 8

Continue on the drive side with 7 more spokes, one at a time, each time from the inside to the outside then *over, over, under and in*. The 3rd set of spokes are now in.



*Figure 41 Lacing step 8*

If you are struggling placing the last few spokes then :

- It is possible that the spokes are too short.
- A mistake has been made in the preceding lacing.
- Some of the nipples on other spokes may not be seated through the rim.
- You selected some spokes from the wrong pile.

At this stage all the spokes should still be relatively loose.

## Step 9

Complete the opposite side of the wheel in the same manner, i.e. insert a spoke from the inside and rotate it back to the rim in the opposite direction to those already placed remembering to weave the spoke. Now there is only one rim hole available to take the spoke. The 4th set of spokes are now in and the diagram below shows the wheel with the full compliment of spokes in both sides. At this stage the spokes in *your* wheel will be loose and bowed and will not look exactly like the diagram below.

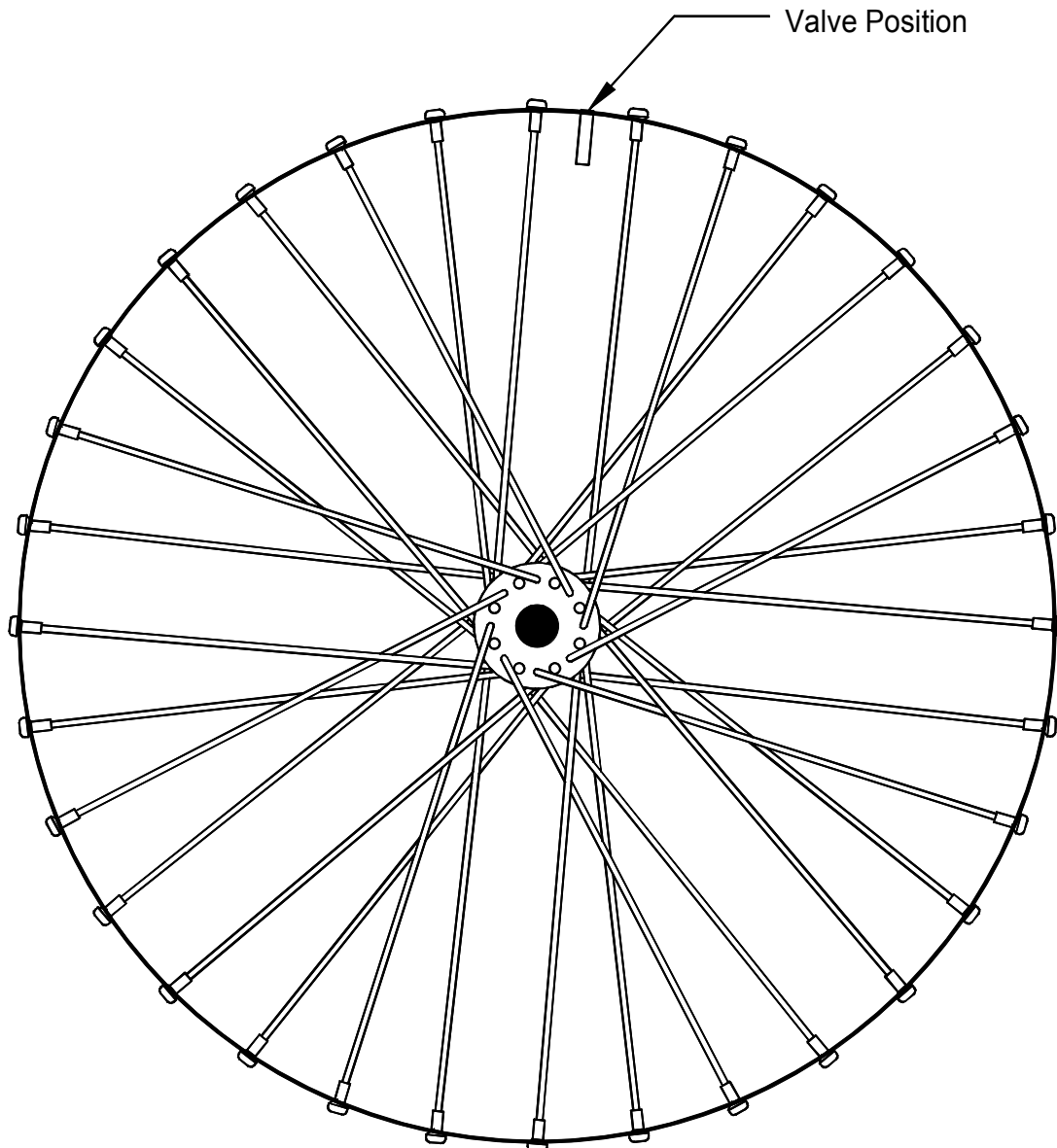


Figure 42 The fully laced wheel

## Check your wheel

- It should have a regular even pattern; the triangles formed at the spoke crossings should be the same size.
- All the spokes should be uniformly loose with no individual tight ones.
- All the spokes should be weaved.
- The valve hole will lie between two almost parallel spokes (to allow easy attachment of the pump).
- If the rim holes are staggered then the spokes should be connected to the correct hub side.

At this stage, particularly if you are new to wheel building you may want to dismantle the wheel and re lace it for practice (without looking at the book). Make sure you keep the drive side and non drive side spokes separate (different lengths remember).

## Notes on lacing

1. The front wheel is laced in a similar fashion. Remember to get the rim label correct by identifying which side of the hub will lie on the drive side, this may seem trivial but is good practice and shows attention to detail. It's not just a case of flipping the built wheel over because the spoke orientation at the hub will change – see Figure 56 on page 73.
2. If the outside spokes were laced first (as opposed to the inside spokes as described) or a complete side laced first you will get tangling problems when placing the remainder of the spokes which slows up the lacing process.
3. The 32 hole 3 cross wheel laced above is just one example from a family of standard crossed wheels. It is easy to adapt the procedure for any number of drillings e.g. 48, 40, 36, 28, 24, and for other cross patterns such as 2 and 4 cross. I'll deal with these later in the Design Section.
4. In Step 3, the spokes in the standard crossed wheel are always placed every 4th hole irrespective of the number of holes or cross pattern. This is because the spokes are arranged in groups of four i.e. two forward and two backward orientated spokes and is why the available drillings are always divisible by 4.

## Completing the wheel

The rim is flat and round to start with and by tightening all the spokes equally it will remain flat and round with the hub central in the wheel and with all the spokes at a similar tension, and if we get our spoke lengths correct then the dish will be very close too. Then all that is required is a bit of fine tuning to finish the wheel.

... and that's how we build them so easily.

The fine-tuning stage might slow you down but all that preceding stuff about tightening the spokes equally is not complicated. Things will get very messy if you don't understand what I've said in the above box and is why many new wheelbuilders arrive at the "fine tuning stage" with an egg shaped wheel that looks like a potato crisp and spend the rest of the week *fine tuning* it (and getting in an even deeper mess).

It is of course easier if you are starting with a brand new rim which should be round and flat to start with and I recommend you start with a new rim for your first wheel. Previously used rims may not be so perfect and will sometimes require more effort to get the wheel finished. A used hub will not pose any problems.

It will help if your hub bearings are correctly adjusted, side to side play in the bearings will make delicate truing difficult because the wheel will wobble about, even a millimetre or so is not acceptable and will make things difficult.

You will also need some tape, paper based tape such as decorators masking tape is best.

Completing the wheel is described in 8 steps. Each step is a logical progression, if you wish to take a break from building then make a note of where you are up to then resume at the same stage when you get back.

The wheel is now placed in the jig.

### 1. Apply adhesive

This only applies if you decided to use adhesive. Previously I recommended that you always build wheels using oil and if you did then you will be arriving at this stage with nicely oiled up spokes. If you are using adhesive then spokes at this stage will be clean and dry.

Take your adhesive (Loctite 222 in my case) and apply a very small blob on each of the visible threads. Spin the wheel in the jig to force the adhesive over all the exposed thread and into the nipple.

## 2. Start taking up the slack

*You are attempting to take up sufficient slack so that the spokes are not loose, that's all, they should have no tension in them and they should not be tight.*

Use the nipple driver to screw down all the nipples equally to the same position. I normally apply a little pressure to the side of the spoke with my fingers so that it enters the rim at 90 degrees allowing the driver blade to release more precisely. The main problem new builders have is keeping the wheel radially true (i.e. round) and I cannot over emphasise the use of the nipple driver. I have **never** built a wheel without the nipple driver and you have no excuse for not making this simple tool (page 30).

With the correct length spokes you will be able to screw down each nipple so that the nipple driver disengages easily.

If the spokes are too short you will not be able to tighten them all equally and will start struggling with the last few nipples. If the spokes start to tighten up before the nipple driver releases engagement do not try to force it because you will be tightening the spokes too much at this stage. If this is the case then use the wrench to back off all *previous* nipples two turns. Continue with the nipple driver on the remaining nipples but remember to use the wrench to back those off too to ensure all nipples are at the same engagement.

If the spokes sizes were correct then the spokes at this stage will still be loose so continue tightening them with the spoke wrench.

For new builders the biggest mistake is turning the wrench the wrong way and this is easily done on a few nipples and often without realising it. Once you make this mistake then the wheel starts going out of shape, it loses its roundness and gets some severe side to side wobbles which can be very disheartening for the new builder, so each time you use the wrench carefully consider which way to turn it. To help you, see my tip for using the Spokey on page 17.

When using the wrench make adjustments a little at a time until you become familiar with the building process and can use your judgement to make larger adjustments when you can recognise the situation that warrants it. A small adjustment is one quarter turn of the wrench (or one eighth when finishing the final truing), a large adjustment is 1 - 2 turns.

Use the wrench to tighten each nipple one turn, go around the wheel again if necessary. It should only need one or two turns at most, any more and the spokes are a little long. At all times use the valve hole as a reference point and always go completely around the wheel, you may want to clearly mark the valve hole with some tape because it is easy to miss it and start another revolution. The natural hand and finger action of using the wrench yields one half a turn and this is my basic unit of measure so if I were tightening the nipple one full turn I would consciously count "one – two" in my mind.

Have a piece of tape handy ready to mark **the next spoke to tighten** if you are interrupted midway or drop the spoke wrench (and also remember how many turns you were giving it). If you lose your position you are in big trouble. I always have a couple of pieces of tape stuck on the wheel jig ready to grab and place on the spoke (for me it is usually the phone ringing or someone calling in the shop that causes me to stop). That's why I prefer paper masking tape because it's easier to rip a piece off when required immediately.

### 3. Align the spokes

At this stage you will have removed the looseness of the spokes and there will be just sufficient tension so that the spokes point in a direct line between hub and rim. **They should not be tight.**

You will notice that the spokes on the *outside* of the hub flange tend to bow slightly outwards away from the hub before taking a line towards the rim. Although this bend will straighten out as more tension is applied it will leave a residual stress in the spoke which will contribute to fatigue failures at the spoke elbow.

The amount of bowing depends on how good a fit the neck of the spoke elbow is in the hub, the tighter the fit the more the spoke will bow.

Take each *outside* spoke in turn and press on the spoke close to the elbow with your thumb so that the spoke takes a straight line to the rim (you should use a glove to protect your thumb). You are physically bending it a little extra at the elbow. This bending does not cause any problem to the spoke (remember making a spoke is brutal process and what you are doing here is mild in comparison).

Sight along the spoke near to the hub to make sure it is straight. Take more care if you are building a wheel where the outside spokes slightly touch the heads of the inside spokes, in this condition it is possible to form a secondary bend in the spoke by pivoting on the other spoke head as you press down the spoke. Also be careful not to pivot on the edge of the hub flange as this too will put an undesirable kink in the spoke close to the elbow.

The *inside* spokes usually have sufficient angular movement to take a straight line path to the rim without any modifications but check all the same. The rear drive side is the one to watch since the inside spokes there take a steeper angle to the rim. If the inside needs adjustment then push the spoke elbows gently towards the hub flange.

If the spokes had been over tightened in the previous stage then the spokes would have been pulled straight with no apparent misalignment but creating an unnecessary stress in the spoke.

The above discussion only applies to new spokes. If you are reusing old spokes and replacing them the same way they were removed from the hub then they will already have the correct alignment and will require no modifications.

Once aligned, the spokes will become slightly looser.

### 4. Take up all of the slack

Tighten the nipples again, one turn at a time, and always one complete revolution of the wheel. Feedback from the wrench will tell you when the spokes are starting to tighten when a slight resistance to turning is noticed although the nipples can still be turned freely. This stage may only require an additional one or two turns of the wrench.

*At this stage the spokes will make a tone when plucked close to the nipple.*

### 5. Improve the lateral trueness

If the spokes were tightened equally as described previously then the lateral trueness will be reasonable but no doubt could be improved. It is always better to work with a wheel that has good lateral trueness since the radial trueness is easier to identify and there is also the benefit

of seeing the wheel taking shape. It does not need to be absolutely perfect at this stage but it helps if you get it fairly close rather than trying to correct large errors later.

Spin the wheel in the jig and position the reference point close to the side of the rim. Identify any local discrepancies where the rim touches or moves away from the reference point and examine the spokes in the immediate vicinity. Slight variations in spoke tensions will be causing the out of true.

Use tone to determine the relative tensions between adjacent spokes, tighter spokes have a higher pitched sound and looser spokes give a rather dull note when plucked (if you have no finger nails then a good alternative is to use a disposable plastic picnic knife or something similar to pluck the spokes). On the rear wheel the drive side spokes will be tighter because of the dishing effect so for rear wheels only compare spoke tone on the same side.

Identify a zone of out of trueness and home in on this area. The out of trueness is likely to be caused by a single spoke that is either tighter (or looser) than its neighbours (on the same side of the wheel).

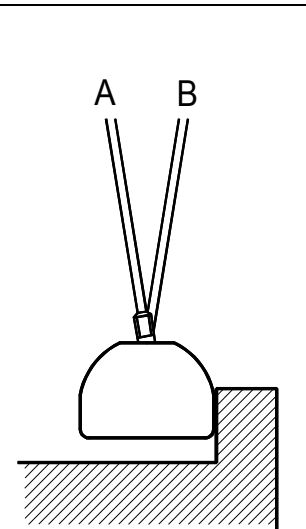
Using tone as the guide slacken any tight spokes and tighten the loose ones, keep the adjustments to half a turn or less because the rim will move easily at this stage. Tightening a spoke will pull the rim towards the appropriate side and slackening the spoke will allow the rim to move away. If all appear to be the same tension then loosen slightly the spokes on one side and tighten the opposite side.

In this example the wheel spins freely except at the position shown where the side of the rim touches the reference point. Check the tension of the spokes in this region then use one of the following actions to correct it :

- i) A spoke on side A may require tightening.
- ii) A spoke on side B may require loosening.
- iii) A combination of the above.

Note, if there is a gap (instead of the rim touching) then spoke B would require tightening or spoke A slackening etc.

More than one spoke may need adjusting to correct an out of true region where the region spans several spokes. If so, remember to reduce the amount of adjustment as you reach the outer edges of the region (i.e. feather the adjustment).



## 6. Adjust the radial trueness

Obtaining a radially true wheel is considered one of the more tricky aspects of wheel building. The rim must be round with no low spots or high spots. If you have been careful in the previous stages then the radial trueness will not be far out, if it's more than 2 mm out of round then take more care next time. You did use a nipple driver didn't you?

Use the lateral trueness gauge (page 24) and place it on the outside edge of the rim. Turn the wheel slowly looking for high spots where the rim touches the gauge. Spokes in this region will require tightening to pull the rim closer towards the hub thus reducing the high spot. It's better to attack the high spots because correcting them requires tightening, i.e we are still moving towards the finished wheel rather than backing off spokes at this stage. Remember to feather out the tightening towards the edges of the region i.e. reduce the amount of tightening as you approach the outer edges of the high spot. When adjusting spokes on a rear wheel tighten the drive side spokes slightly more to maintain lateral trueness (due to the difference in spoke angles on the drive/non drive sides).

Now look for low spots where there is a gap between the rim and reference point, spokes in this region will need loosening a little, again make sure to feather the adjustment.

In all cases make adjustments a little at a time, each time checking the rest of the wheel since adjustments in one region can cause radial movements in other regions of the wheel. Be careful not to make the spokes too tight because it makes things difficult and you can end up with dozens of tiny bumps that are impossible to get out.

The region around the rim joint may not be perfectly round due to the manufacturing techniques used in making the rim. On rims that are joined by welding an otherwise good and round rim may have a little material removed (or added) in the welded region causing a false error which can be disregarded (because the important tyre seating region will be perfectly round). Rims that are pinned may not butt up squarely and leave a little high spot. You can try to improve it but if it requires overly tight or loose spokes compared to adjacent spokes then it's much better to try and maintain similar spoke tensions and tolerate a small localised radial error (which will not be noticeable when riding the bike).

As you turn the wheel be aware that the jig will exaggerate the out of trueness. Closer examination may reveal it to be satisfactory and this is described later in *Wheel tolerances* on page 55.

After adjusting the radial trueness re-check and adjust the lateral trueness.

## **7. Equalise the spoke tensions**

At all times in the wheel building process you are endeavouring to keep things equal and in balance and this is particularly important with spoke tensions because it helps prevent them coming loose when the wheel is used. It is possible to produce a nicely true wheel but with spoke tensions all over the place, a few low tension spokes could be compensated for by a few overly tight ones and when the wheel is used those loose ones will become looser and the trueness you thought you had will soon disappear.

You may not have tightened the spokes equally in the initial stages or there could be minor differences in the spoke lengths so a quick check is required.

Starting at the valve hole pluck a few spokes to gauge the average tone, for dished wheels treat each side separately since each side has a different tension and consequently a different tone.

Remember that although the wheel is currently laterally true some spokes may be making a bigger contribution whilst others are not pulling their weight. If you find a slack spoke then it needs tightening, but to maintain lateral trueness its two neighbours will need slackening by half as much as you tightened the central spoke. Similarly, if you find a tight spoke then back it off a

little and tighten its neighbours. Note, the neighbouring spokes are on the same side of the wheel and not the immediate neighbours which are from the opposite side.

It will take at least two passes round the wheel to equalise the tensions. It is unlikely you will get the pitch identical since the pitch is very sensitive to tension, just get them all close. Again check and adjust the lateral trueness which should not have moved that much.

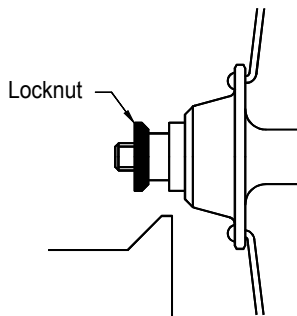
## 8. Check the wheel dish

The wheel dish should be checked regularly, more so as you start the final tensioning of the wheel. This will ensure that the rim in the finished wheel is central between the locknuts and it applies to both front and rear wheels. The wheel must be reasonably true laterally before checking otherwise local discrepancies in lateral trueness can give a misleading indication of dish.

When checking the wheel dish for the first time some error will be noticed and the amount for a dished wheel (rear or disc brake front) is closely related to the spoke lengths used. Since we cannot get spoke lengths in fractions of a millimetre to suit the theoretical lengths some dishing error is to be expected. If the spokes were near to the ideal length then the dish will be perhaps 5mm out (or closer). If you had to compromise when selecting your spokes and one side was 1 or 2mm different from the ideal length then the dish will be out a lot more. If I knew I was building with spokes that were too long on one side then I would compensate for this when taking up the slack when using the wrench in Step 2, ie. the long side would get more turns than the other side, or if they were short then they wouldn't get as much. You don't want to be fixing large dishing errors when the spokes are tight, try to do your *fixing* earlier if you are using less than ideal spoke lengths. If you believe your spoke lengths to be correct and have a massive dish error then make sure they went into the correct side when lacing the wheel.

Take your dishing tool and check the wheel. If the locknut protrudes further on one side than the other then spokes on that side will need tightening to pull the rim over and push the axle back, see Figure 43. This takes some getting used to and there is the real danger of adjusting the wrong side. The other thing to remember is that it does not need much tightening to correct dishing errors, start with half a turn and you will be surprised how far the rim will move. Correcting small dishing errors will often require a fraction of a turn and you can easily over correct.

The standard front wheel with the same length spokes either side should pose little problem if you have tightened all the spokes equally but it can easily wander to one side requiring a small adjustment to correct it. Remember that front disc wheels will have some dish.



The gauge was first placed on the opposite side of the wheel and adjusted so that it just touched the outside edge of the locknut. It is now shown here on the other side of the wheel and the diagram shows how this wheel is over dished. The spokes on this side will require tightening.

Figure 43 Dishing error

**Maintaining dish** : Once the dish has been corrected (quite easy at this stage when the spokes are not too tight) you must then be careful because the dish can very easily go out again, especially the rear wheel.

Maintaining dish on the *rear wheel* (or front disc brake wheel) is not as simple as going around tightening all the spokes the same amount, spokes on the drive side (or front disc, rotor side) require slightly more to maintain the dish because of the steeper angle of these spokes. For our rear wheel it is therefore better to go around the wheel in two passes, first go around the *drive side* spokes say half a turn then the *non drive* side spokes a fraction less.

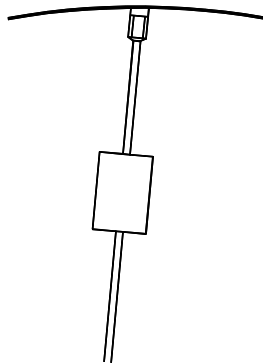
*At this stage I consider the wheel to be in a state of balance, it is true (radial and lateral), has equal spoke tensions and the dish is correct. All that is required is to tighten the spokes to achieve the correct spoke tension whilst maintaining dish and trueness.*

Before starting the final stage of completing the wheel it is necessary to understand two importance aspects in the wheel building process:

- i) Spoke twist.
- ii) Stressing the wheel.

### ***i) Spoke twist***

As you turn the wrench the nipple should tighten itself on the spoke threads but due to friction in the threads there is the tendency for the spoke to twist as well as the nipple tighten. The amount of twist is dependent on the type of spokes being used, whether the threads have been lubricated and how tight they currently are. Slender butted spokes will twist more than the plain gauge one which is fairly resistant to twisting. You need to be aware if the spokes are twisting so you can compensate for it when tightening them and then release any twist (that would otherwise remain in the spoke).



They way to check for spoke twist is by placing a piece of tape along the spoke at a position as close to the rim as possible without interfering with the wrench forming a flag (the spoke may need cleaning for the tape to adhere).

*Figure 44 Checking for spoke twist*

Before turning the wrench make a mental note of the original position of your tape flag and notice if it starts rotating in the same direction as you turn the wrench. This shows that the spoke is twisting rather than the nipple tightening. When the flag stops rotating there is sufficient torsional resistance in the spoke to cause the nipple to turn (relative to the spoke) and thus tighten the spoke. At this point you can then turn the wrench the required amount to tighten the spoke. Release any spoke twist by turning the wrench in the opposite direction until the flag returns to its original position. It is not necessary to tape every spoke since the spokes will react similarly but since it is easy to do replace the flag every couple of spokes to monitor the twist. The tighter drive side spokes will twist more.

If you are using bladed or other profiled spokes then spoke twist is easily visible and it is even more important that you un-twist any spokes to maintain their correct orientation otherwise any “aerodynamic” benefits will be wasted. Bladed spokes such as the Sapim CX-Ray need a special tool to physically prevent them from twisting whilst you tighten them.

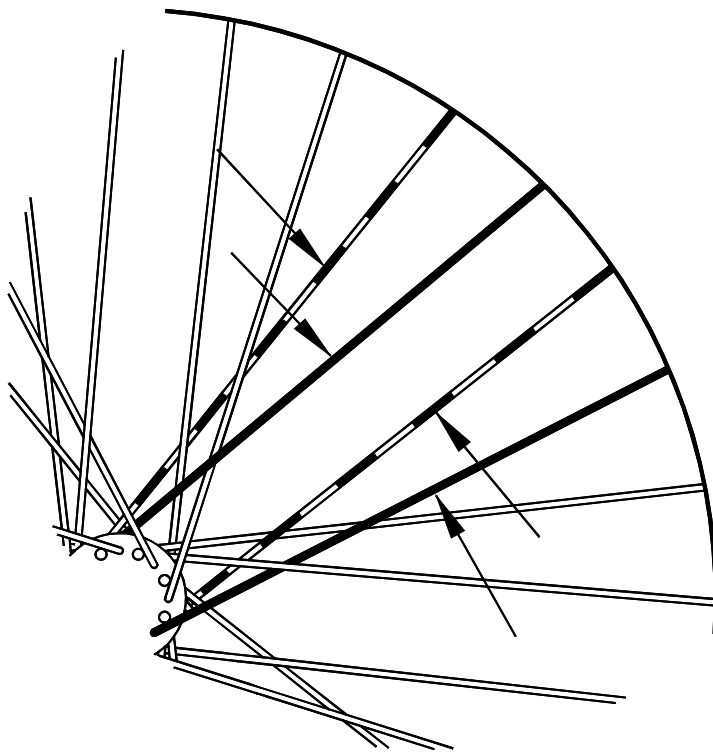
In the previous building stages there will be very little spoke twist due to the lower tension in the spokes but look out for it in the next stage. If you suspect your spokes already have some residual twist in them then you can use the tape flag to return them to the neutral position, i.e. the flag rotates one way, then the other as you turn the nipple.

## ***ii) Stressing the wheel***

All the methods used for stressing a wheel place extra localised tension on the spokes. Applying a stress to the wheel releases any twist in the spokes, it makes sure the nipples and spoke elbows are firmly seated in the rim and hub and more importantly the procedure has a beneficial effect on reducing the effect of fatigue failures at the spoke elbows.

Stressing the wheel is not a once off operation and should be used several times during building. Although not required during the building stages already described it will be necessary during the next stages as you start the final tensioning of the wheel. After the first stressing operation the wheel will probably lose some of its lateral trueness which will need correcting and then further stressing operations will cause little or no out of trueness as the wheel nears completion.

To stress the wheel grasp two pairs of spokes and squeeze them together as shown in Figure 45 going all round the wheel squeezing in groups of four, you’ll need your gloves (page 30) to protect your hands. This technique applies a lot of force to the spoke elbows which enables a superior stressing operation. Don’t worry, you will not break or damage any of the spokes no matter how hard you squeeze (unless they were faulty spokes or old spokes previously damaged, so see the warning on page 53).



Choose the two almost parallel spokes on either side of the wheel and firmly squeeze both pairs together simultaneously at midpoint, then move around the wheel from group to group until you complete the wheel.

Note, the near side pair are shown in black, far side pair shown dashed.

Figure 45 Stress relieving two pairs of parallel spokes

The other commonly used method I see people using is to stress the wheel by placing the wheel flat on a hard surface with the axle of the hub supported on a block of wood and pressing down on the rim diameter with your hands at several different places before turning the wheel over and repeating the process. I'm describing it here because I expect you believe this is a required operation. It is not and I never use this method. This is a poor method and does not adequately stress the spokes. You are slightly stressing the *upper* spokes in the region where your hands are which become tighter during this operation. The lower spokes lose tension and any residual twist in them is released and you will hear a tinkling sound as they unwind (but they should have little or no twist in them if you have tightened the spokes correctly and compensated for the spoke twist). Many people attribute the tinkling sound to the stresses being relieved and take comfort when they hear it, do not be misled (do not use this method anyway).

## 9. Final tensioning

This last stage is concerned with finishing off the wheel by bringing the spokes to their final tension.

**Warning.** As you tighten or stress the spokes do not look into the rim channel. A spoke that breaks can fly out of the rim and hit you in the eye.

How tight should the spokes be and do you require different tensions for different end uses e.g. touring, racing and off road? It is obvious there should be sufficient tension to prevent the nipples from working loose and it is also important to note that tighter spokes make a stronger wheel. You will not obtain a softer ride by using lower tensioned spokes the only effect being a less strong wheel, so for *all* wheels there is only one tension and it's tight.

The term *tight* though is ambiguous and difficult to define easily. You cannot use tone to quantify tension because tone only identifies relative differences in tension between spokes on the *same* wheel i.e. one spoke is tighter than or slacker than the other, there is no correlation between the sound it makes and whether it is sufficiently tight, plus different sizes and types of spokes make different sounds. Neither should you be guided by the resistance in turning the spoke wrench since this is influenced by many factors such as friction in the components (e.g. aluminium or brass nipples), type of rim eyelets, the size of the wrench and the available leverage and how strong you are.

There is a decent margin between sufficiently tight and theoretically the tightest the wheel can be and as long as you drop into this zone you will have a good reliable wheel.

The best place to start when judging the correct tension is to examine a similar wheel you know to be good and reliable that you know to be trouble free and compare the spoke tension to the one being built (similar means the same number and type of spokes - plain gauge or butted, and a similar type of rim). Choose a pair of almost parallel spokes on the reference wheel (on the same side) and flex them at mid point and make a comparison with your own wheel. Do not compare the tone of the spokes to those in the comparison wheel, this tells you nothing unless it's a brand new wheel of the same specification with no tyre on. As you build more wheels you just get to know what is tight and what is slack. To help you build up your own knowledge and understanding always take the opportunity to check the spokes in other people's wheels but do not assume those wheels are correct since it is always easier (and quicker) to build a wheel with spokes at a lower tension and you will come across many examples of these. Note also that the relative spoke tension is different for the front, rear and rear drive side so only compare like with like.

Can they be too tight – yes, but it's not the spoke that is the limiting factor because spokes have an easy life in the wheel and do not reach anywhere near their limits of tension (assuming you are using good quality spokes). The limiting factor is the rim that is subjected to extremely high compressive forces and it can only take so much before it starts to lose its shape.

When talking about the rims compressive limit it does not mean the spokes are pulling out of the rim because that won't happen. Imagine cutting through the rim and the compressive force is the one that forces it back together. That's why simple pin jointed rims are strong, it's the compressive force that holds the joint solidly together and why a welded joint offers no benefit to strength.

As you tighten and stress the wheel there should be little change in lateral trueness. If it goes significantly out of true after stressing in the latter stages of final tensioning then it is likely the spokes are too tight and the rim has reached its compressive limit. In this case it is wrong to correct it by further tightening so back off all spokes half a turn then make minor adjustments to finish the wheel.

The main variable here is the type of rim, the narrower larger diameter road rims cannot take as much tension as a smaller diameter mountain bike rim, similarly a rim with a larger cross section such as aero rims can take higher spoke tensions. You will never buckle a mountain bike rim through spoke tightening because they are just too strong. On a mountain bike rim spoke twist is a good way of judging when to stop and if it twists half a turn then it's pointless going further, on a road rim watch out for the lateral trueness as your indicator (described above).

For the same rim the spokes in a 32 spoke wheel will be tighter than those in a 36 because the total tension in the wheel will still be the same but distributed over less spokes in the 32 spoke one and hence they are tighter.

You need to keep going around the wheel tightening each spoke half a turn until you consider the wheel is sufficiently tight. With each rotation of the wheel and after each stressing operation always check and adjust the lateral trueness and check the dish.

A special tool does exist for measuring the tension in a wire spoke. Since I have not used one of these tools I cannot comment on its usefulness. If you do obtain one then make sure it is calibrated for your specific spokes by checking with the tool manufacture who will also advise on numeric tensions to use.

The radial trueness is not going to wander any great deal and it should maintain the accuracy you achieved in the previous stage, if necessary make any small adjustments. If there are large errors in radial trueness then this is not the stage for fixing them, in fact it will not be possible to. Once the spokes are approaching their correct tension then it will be too difficult to correct any large errors (radial, lateral or dish) in which case it is necessary to slacken off all the spokes and start the tightening process again.

The last adjustment to lateral trueness will just require a fraction of a turn on the occasional spoke. ***The wheel is finished.***

The stages for building the wheel are summarised on page 92 and will serve as a reminder when building future wheels since you may be tempted not to re-read all the detail presented in this section and miss out a vital operation.

## Wheel tolerances

It should always be your aim to build perfectly true wheels every time, but for new wheel builders and even for experienced builders like myself a wheel with zero errors is impossible to achieve. I know some people brag about how true they get a new wheel but my stock answer is "give it to me and I'll ride it for 100 miles, then well place it back in the jig to see how true it is".

So how good must they be? As with all manufactured items there are acceptable errors or tolerances. A wheel that is built to a tolerance and stays within tolerance is far superior to one that is perfect in the jig but goes significantly out of true after being ridden a short distance and needs constant attention.

When viewed in the jig or using the dishing gauge any errors will always appear greatly exaggerated as your eye homes in on massive zones of light between the wheel and reference

points. Careful measurements will show that you are often dealing with very small dimensions and with a tyre on and the wheel placed in the bike the errors will look insignificant and will certainly go unnoticed to the rider.

The following measurements are a guide to good trueness, as you become more proficient in wheel building you will continually try to improve on these: lateral trueness 0.2mm, radial trueness 0.4mm, dish 1mm (difficult to measure so use a visual assessment). Remember that with dish, that 1mm error is distributed 0.5mm either side which is insignificant and is far more accurate than the bike frame and dropout alignment.

Optionally, use feeler gauges (obtainable from engineering suppliers) to measure the gap between the reference points and the rim when checking lateral and radial trueness. Once your eye is in tune then a visual inspection will suffice, if it looks true then it will be true. I used feeler gauges once, just to see what a 0.1mm gap looked like and from then on it was just a visual inspection.

## How long should it take

There's no answer to this because it takes as long as it takes to get a good reliable wheel. You are aiming to build a wheel that you are satisfied with. If you build a wheel that meets your requirements then you have a quality wheel and the time it took to build is not important. My advantage is that I know when to stop, I know when no more effort will make the wheel any better, but that comes with experience that you will start to gain. Plus I've had lots of practice and know how to build a wheel without consulting a book every few minutes and I never turn the wrench the wrong way ;-). Don't be impressed by anyone who boasts about how fast they can build a wheel because there's a good chance they are building poor wheels that require time consuming maintenance to keep them running.

## Testing your wheel

Once built you should never have to touch it again which means you **never have to re-tension it** after a few rides. So barring any accident damage the wheel will stay as good as the day it was built to the day the rim wears out through natural wear and tear. However, in your early wheelbuilding days I propose the following test routine.

For each newly built wheel you should adopt a standard test routine that will enable you to monitor your progress as a wheel builder. The further you get down the test regime the better the wheel builder you are likely to be. At each stage you should check the lateral trueness that will serve as a useful indicator of the general state of the wheel.

A typical standard test would be :

1. The first few pedal strokes.

If you hear a tinkling sound then the spokes had some twist in them that should have been released in the building process. The spokes should not make a sound. The sound comes from movement of the nipple at the rim interface or within the spoke threads. That movement will likely change the nipple thread engagement and cause the wheel to lose a bit of trueness. Also the untwisting of the spoke releases a little tension, which also contributes to losing some lateral trueness.

2. After a short distance of gentle riding.

If the wheel loses its trueness then the spokes were not properly stressed during building. Spokes may also have had unequal tensions, insufficient tension or far too much tension for the particular rim.

3. After a few rides.

If you are a new wheelbuilder you may have to make some *minor* adjustments (usually tightening one or two spokes at most), this is acceptable and should only need doing once. What is not acceptable is if you are constantly making adjustments or if any of the spokes break, in either case you will have to re-examine your building technique. If you cannot build a reliable 3 cross wheel with 32 or 36 spokes then it is pointless trying wheels with less spokes or any other lacing pattern. Learn the basics first.

4. Problems galore!

If you do experience a lot of problems when using your wheels then make sure they are suitable for the intended purpose, it would be unreasonable to expect a lightweight road rim with 28 spokes to withstand rough use by a strong rider or carrying heavy loads.

If you have **ANY** doubts about how good your wheel is from a **SAFETY** point of view then **do not ride it.**

Instead get it checked by a competent cycle mechanic.

## 5. Repairing

It is surprising the amount of wheel damage that can occur before it becomes apparent to the rider and unless you inspect your wheels regularly many damaged wheels will go unnoticed. It is important to check your wheels to identify any potential problems and take corrective action before they develop into something more serious. This is particularly important for the racing cyclist where a broken wheel can lose a race, for the tourist where a badly damaged wheel can spoil a trip and mountain bikers who can end up with a collapsed wheel. Many wheels are good from the day they were built to the day they wear out through natural usage requiring little or no attention, so do not think it is a constant struggle to keep your wheels in trim.

### Checking the wheel

Checking the wheel is simple enough :

- Spin the wheel in the bike and check its lateral trueness using the brake blocks as a reference (for disc brake wheels temporarily attach something using tape to act as your reference). Trueness is a big indicator of the general state of the wheel, if it's badly out of true then something is wrong, a loose or broken spoke or a broken hub or rim.
- Check each spoke to see if it seems as tight as its neighbours. Plucking them to check for similar tone can be useful but beware of factors that will give a false note such as dirty spokes and the damping effect of the tyre. What you are looking for are obviously slacker spokes and not ensuring that they are all pitch perfect.
- Wipe the surface of the rim and look for uneven markings and cracks both on the braking surface and other regions of the rim particularly around the rim eyelets.

The typical faults to look for are outlined below, how severe you judge your findings will determine the level of corrective action necessary. As well as identifying a fault, try and understand how it happened in the first place to prevent regular occurrences of the same problem.

The more problematic wheel is the rear one because of its weaker design due to dishing and carrying a greater proportion of the riders weight (and touring luggage). In contrast the front wheel should not suffer too many problems, it is a stronger design (dishless), it carries less weight and rim damage is usually reduced by the rider guiding the front end around potholes or other obstructions, whilst the rear wheel usually hits whatever you are trying to avoid. The exception here are mountain bike front wheels, particularly those dished to accept a disc brake. Going through a corner with a major front end sideways slide (i.e. you made a mistake in cornering) puts a massive sideways load on the wheel and even the best made wheel can collapse.

## Loose spokes

A wheel losing some of its lateral trueness is usually caused by a spoke coming loose. It is better to tighten a loose spoke as soon as possible because adjacent spokes will start to lose their tension leading to a rapid deterioration of the wheel (see *Lateral truing* later in this section). Check that the spoke is not coming loose through a rim failure where the rim is cracked and pulling apart in the region of the eyelet.

## Damaged spokes

These are spokes that are still in one piece but have obvious damage such as kinks or surface indentations. A few indentations along the length of the spoke from stones hitting the wheel won't cause any problem, remember that Sapim stamp SAP into their spokes close to the elbow without weakening the spoke in any way (see Figure 7 on page 12). The one you should avoid at all costs is the chain drop.



*Figure 46 The dreaded chain drop*

Dropping the chain between the largest rear sprocket and the hub whilst changing gear, or bouncing it off on rough ground will cause the chain to gouge the spokes close to the spoke elbow. This will cause a degree of out of trueness and the weakened spokes will eventually break through accelerated fatigue failure. If you regularly damage your spokes in this way then consider fitting a plastic spoke protector. It's a pity spoke protectors have an un-cool image because they are a piece of ugly cheap plastic often found on entry level bikes. Now if someone made a nice high tech version then everyone would rush out and fit one and we could forget about chains harming our wheels.

If you have dropped your chain replace any severely damaged spokes or inspect them regularly to see if they break, others with only slight damage along the length can be left alone. In Figure 46 the chain hit the shoulder of the lightweight double butted spokes of the 2mm 1.5mm type. Two spokes snapped immediately and the others were severely gouged, needless to say his race was over. If he had asked for normal butted spokes then the wheel would still be in a sound condition and the race could have been completed – another case of lightweight components slowing you down!

## Spoke breakages

A spoke can break for no apparent reason with a clean break across the spoke elbow. This is due to a fatigue failure in the spoke material caused by the fluctuating load on the spokes as the wheel rotates. A fine crack will appear and start to propagate across the spoke over a period of time (depending on how often the wheel is used) ultimately leading to a fracture. Spokes do not break due to the power exerted by the rider, it is because the spokes are already in a severely weakened state due to fatigue cracks and an extra push on the pedals will be sufficient to snap the un-cracked remainder of the spoke. It tends to occur at the spoke elbow because this area has the greater concentration of stress. This type of break should not happen in the first place and can be virtually eliminated by using the correct building technique described in the *Building* section (aligning the spokes and stress relieving).



Figure 47 Fatigue crack

If a spoke has failed through fatigue then carefully examine the other spoke elbows on the same wheel and you may see hairline cracks appearing on apparently sound spokes (see the photograph) - their days are numbered too. If only one spoke has broken then replace it but mark it with tape and monitor the wheel's progress. If other spokes start to break then it may be worthwhile rebuilding the wheel with a complete set of new spokes. With all the care you lavish on your building you cannot legislate for a manufacturing defect in the spoke material that subsequently causes it to fail, although this is very rare these days.

It's quite common to hear and read about spokes snapping. The **wrong** advice people give to cure spoke breakages is to use bigger spokes, either going to plain gauge (because they *look* stronger) or using fatter butted spokes that usually go by the name of tandem spokes with a diameter of 2.3mm at the hub end rather than the standard 2mm. The correct advice is to examine your building technique and make sure you stress relieve the spokes.

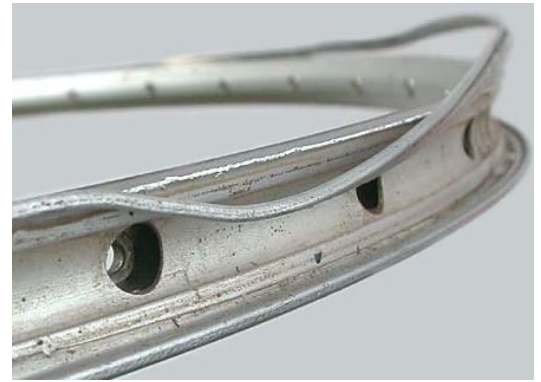
## Rim wear and damage

Rims eventually wear out and they have a limited life and like tyres they are consumables. You are going to be spending more on tyres than rims so it's not a major issue throwing out an old rim. Remember that the same spokes will be used with the replacement rim so keep a couple of spare rims in your garage. It's nice to know that you can wreck a rim on a Saturday ride then pop a new one in ready for Sunday.

Some aspects of cycle sport such as off road riding are hard on rims so it may be advisable to use a cheaper rim i.e. good quality but no expensive features such as surface treatments and fancy colours and replace it when the expected damage occurs. Since you will be doing the replacement work yourself the only cost is that of a new rim every now and then.

Rim damage is the most common thing to look out for on a wheel so it pays to check them regularly.

Look out on older rims for concave sides, cracks and non uniform surface markings on the braking surface which suggests the metal has almost worn through. In Figure 48 the sidewall of this rim was so thin it led to a failure whilst riding the bike that caused a section going around one third of the rim to rip off instantaneously. When this happens it is very dramatic and often accompanied by a loud bang and would be very dangerous if you were riding fast at the time, plus it means your days riding is over. So check your rim for wear and if in doubt replace it.



*Figure 48 Worn out rim!*

Cracking of rims around the spoke eyelet where the spoke is pulling itself out of the rim is not a result of excessive spoke tension, it is a result of a poorly designed rim resulting in fatigue cracks. A rim in that has cracks will need replacing immediately. The crack in Figure 49 was interesting because this was a mountain bike rim that I'd never had any problems with and there were several cracked eyelets on this one. It turned out that the customer used his mountain bike for commuting to work and used narrow section high pressure tyres and after 3000 miles the cracks started happening. The rim manufacturer said the rim was not designed for this type of use and that under normal mountain bike conditions using wide low pressure tyres it would be fine (which it was). The rim was replaced by a stronger one, i.e. one that was heavier with more metal on it – the original seen here was a very lightweight XC rim.



*Figure 49 Fatigue crack in rim*

Check for any flat spots resulting from impacts and if any have caused the spokes to lose some tension then tighten them up. Although the flat spot will remain in the rim it is unlikely it will be noticed whilst riding so there is usually no need for anything more elaborate. If the impact has been severe then check that the local flat spot does not cause the brakes to chafe the tyre causing an early tyre sidewall failure which can be quite dramatic and dangerous.

Beating out indentations or trying to bend a crash damaged rim back into shape is troublesome and can often make things worse, at most it will only be a temporary repair until the rim can be replaced. In general just keep an eye on the rim and if it appears too far gone and it starts to affect the ride quality or has safety implications then it is better to replace it. It is perfectly acceptable to use the same spokes if using a similar rim.

## Hub damage

Not a lot to say about hubs they just seem to go on working. I've seen a few hubs where the flange thickness was so thick it made placing the spokes into the hub very difficult. If you take a hub from the big players you should be trouble free. Don't forget to look after your bearings and renew any worn out "sealed" cartridge bearings, remember that these are *sealed* to keep the grease in and not water out so if you ride in wet conditions or jet wash your wheels (don't) then water will get in and contaminate the grease and rust will set in. To prolong the life of cartridge bearings you can periodically prise out the plastic seal and insert some fresh grease then push

the seal back. The cup and cone bearing and axle design found on Shimano type hubs is a very good design and some would say better than cartridge bearings, however all too often I see loose bearings and rusted bearings. Get yourself some cone spanners and periodically back off the cones and push some grease in. When tightening the cones don't do them too tight because when placed back in the bike the action of the quick release compresses the axle and tightens them a little more.

## Dismantling an old wheel

There are three reasons for dismantling a wheel and each has a particular technique for dismantling it as described below. In all cases remember to remove the sprockets and disc brake rotors first otherwise you will have difficulty removing them later. Once dismantled follow the instructions in the *Building* section for rebuilding the wheel.

### 1. Replacing the spokes

The spokes may be damaged through a poor initial wheel build i.e. you are continually replacing broken spokes, or you have damaged them yourself such as dropping the chain off the largest rear sprocket and gouging them. In both cases it is usually better to rebuild the wheel with new spokes using the existing hub and rim.

Before dismantling examine the spokes in the wheel and see if they were the correct length (they should finish flush with the top surface of the nipple). Any spoke length errors can be compensated for when purchasing the new spokes so do not perpetuate any errors by using the same length replacements.

Start dismantling the wheel by using the wrench to back off the spoke tension a little at a time going around the wheel backing off a turn on each nipple, then a couple of turns, going around the wheel several times until all the tension is released. You then have the option of using wire cutters (see Figure 50) to quickly take out the spokes or continuing with the wrench and nipple driver to completely dismantle the wheel.

If you do decide to cut out the spokes then **ALWAYS** back off all the spoke tension with the wrench and **ALWAYS** keep the rim tape on whilst cutting because you **NEVER** want a spoke to fly out of the rim and hit someone (or yourself).

Suddenly releasing a fully tensioned spoke can also damage the rim that you intend to re-use.

Clean the hub and rim ready for rebuilding. When rebuilding you **must** ensure that the spokes are placed through the hub so that the spoke elbows match the previous indentations in the hub flange. Putting the spokes in a different orientation will pull the hub flange in the opposite direction and will damage the hub flange and it will increase the likelihood of the flange failing through fatigue.

Replacing just a single spoke is easy but don't worry too much about bending the spoke along its length as you push it through and work it around the opposing spokes. It may look banana shaped but you can bend it back again with no harm whatsoever to the spoke.

If you replace a single spoke then oil the rim eyelet and spoke thread, lace the new spoke in the wheel, attach a nipple, take up the slack then *Align the spoke (page 47)*, then tighten and true and finally stress the spoke (*page 52*) squeezing the two pairs of parallel spokes that contain your newly placed spoke.

Here's a special note for replacing a straight pull spoke. This is based on my work at race events where I tended to fix most things that were brought to me from riders other than the race team that I was there to support. Someone came to me with a very old wheel in poor shape that needed truing up ready for the next race. He had to use this because his good wheel – his Mavic DeeMax, had broken two straight pull spokes and he obviously knew there was an issue with obtaining replacement spokes. I said let's fix the DeeMax. The solution is to bend an elbowed spoke straight and it works very well. The guy was very pleased with his race ready DeeMax which performed perfectly in the race. I told him to get some genuine replacement spokes as soon as possible. Enough of straight pull spokes, chances are you'll never need to go anywhere near them.

## 2. Replacing the rim

The hub and spokes are perfectly okay but the rim is in a poor state and needs replacing. Remember that a set of spokes will last a very long time and will easily outlast many rims so there is absolutely no reason to throw the old spokes away because using new ones will offer no advantage. The old nipples are fine too providing they are brass. I was not keen on reusing aluminium nipples.

I only reuse the spokes if the original wheelbuild was my own because I would know that the spokes were good quality and that they were not previously damaged through bad building. Any other previously used spokes with an unknown history would be thrown away.

We are assuming here that the replacement rim is the same or is another brand or model that has the same over spoke diameter in which case the existing spokes will be the correct length and can be re used. If you are using a different rim then measure the over spoke diameter of the new rim to see if the existing spoke lengths are suitable (see *Appendix 1* on page 83 for the method of measuring rim diameters).

There is no need to completely dismantle the wheel and there are benefits from not doing so. Oil the inside of the eyelets on the new rim. Back off the spoke tension in the wheel using the wrench by going around several times loosening each spoke. Then tape the new rim to the side of the old rim so that the valve hole positions are identical. Now transfer each spoke across to the new rim i.e. take out the nipple and replace it in the same hole in the new rim, dab a bit of oil on the spoke thread then re-attach in the new rim a couple of turns. Doing it this way has the advantage that you do not change the orientation of the spoke elbows in the hub flange. Just consider the hassle if you completely dismantled the spokes from the hub. You would need to segregate all the spokes and for a rear wheel that would be four bundles : inside (drive); inside (non drive); outside (drive) and outside (non drive), a standard front wheel will have two sets: inside and outside (and a disc front four sets). The spoke elbows will have taken a particular bend and it is important to replace them in a similar fashion in the new wheel that can be time consuming.

There is a case for cutting out the spokes and it's purely a commercial or time related decision because cutting out the spokes is a lot faster than the transfer method described above. An example would be doing race service where a team rider requires a new rim quickly (you'd think

teams would be equipped with plenty of spare wheels but this is not usually the case). Given the chance I always reuse spokes as previously described – even for professional riders.

If you do decide to cut out the spokes then **ALWAYS** back off all the spoke tension with the wrench and **ALWAYS** keep the rim tape on whilst cutting because you **NEVER** want a spoke to fly out of the rim and hit someone (or yourself).

For information, the cutters I use are the C.K. model 4371A because standard pliers or other more delicate wire cutters will struggle with tough stainless steel. These go through a spoke with little effort. In the photo they look like massive bolt croppers but in real life they are a small single handed tool.



*Figure 50 The last resort!*

### 3. Replacing the hub

Whatever the reason for replacing the hub, the existing spokes and rim will be used for rebuilding with the replacement hub. The existing spoke lengths will be suitable providing the new hub has a similar geometry. A chunk of material ripping out of the hub flange may be covered by the manufacturers warranty so check first before purchasing the replacement.

Again back off the tension as described and continue to remove the spokes from the **rim only** leaving the spokes still in the hub. The reason is that they are nicely segregated and when you come to rebuilding just pull a spoke out of the appropriate side (it helps if you gently shake out the weavings first), the spoke elbows will have taken a particular bend and it is important to replace them in a similar fashion in the new hub. Again, the old brass nipples should be reusable but old aluminium nipples will need replacing.

## Lateral truing

If the wheel is excessively out of true due to a “riding incident” that results in some excessive warping (like a big crisp) then no amount of spoke tweaking is going to fix it. You can try and flatten it a bit by pressing down on the circumference of the rim then get some more trueness by adjusting the spokes but your spoke tensions will be way out with some excessively tight ones and some very loose ones. At best you want to get something that you can ride carefully home and put a new rim on.

So the procedure described here is for sorting out a wheel that has lost some of its lateral trueness i.e. it has a side to side wobble that turned up from **normal riding**.

This exercise can be carried out on the bike using the brake pads as a reference or the wheel placed in a jig, there is no need to remove the tyre.

Spokes do not tighten themselves in use so it is not usual to start loosening spokes to correct the wheel.

The out of true is usually caused by a spoke (and usually only one) losing some of its tension.

Spin the wheel and note the point of maximum deviation.

Identify the offending spoke which will be on the same side of the wheel in the region where there is maximum deviation *away* from the reference point. Spokes with a lower tension will either feel loose or make a dull sound in comparison to adjacent spokes when plucked close to the nipple.

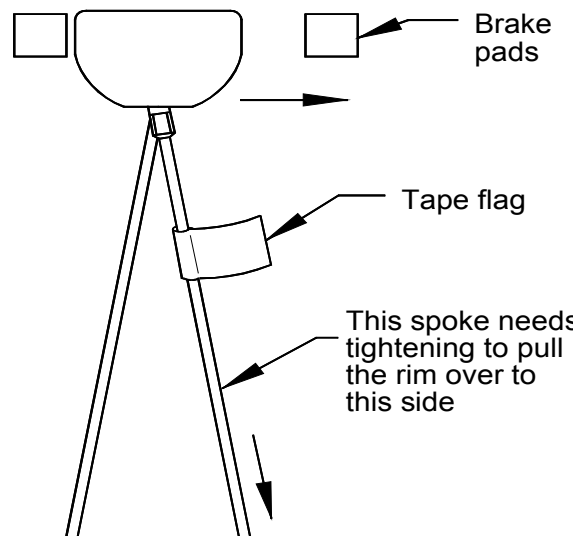


Figure 51 Adjusting lateral trueness

The spoke will require tightening to pull the rim back towards the central (true) position. Before using the wrench make sure you know which direction to turn it. It becomes second nature after a time but it can trap the unwary who sometimes turn it in the opposite direction which makes the trueness even worse.

The use of tape flags was described within the discussion on *Spoke twist* on page 51 and it should be read again since flags are equally important here to check if the spoke is twisting rather than tightening. The flag serves an additional purpose here, it marks the spoke to adjust, if over tightened causing out of true in the opposite direction, you can easily locate it and back off a little tension. Identify the likely spoke and apply a flag by firmly wrapping a piece of tape over the spoke to prevent it flying off.

Note, whilst tightening, the spoke friction may suddenly release with a crack with the flag snapping back to its original position and the spoke will be tightened an amount based on how far the wrench was turned. You may find this condition on well-used wheels where the nipple has become firmly attached to the spoke threads.

It is better to make several small adjustments rather than one big turn of the wrench because it is very easy to over tighten the spoke and cause the wheel to go out of true in the opposite direction. The mistake then would be to start tightening an opposite side spoke which although curing the trueness will also have caused the radial trueness to go out resulting in a localised flat spot. The correct solution is to back off the spoke that you inadvertently over tightened.

Turn the wheel slowly backwards and forwards over the region you are working on and note the improvement in trueness. If the wheel is still out of true and the spoke is still not as tight as its neighbours then give it another half turn and possibly look for other slack spokes in the immediate vicinity.

## Notes on truing

1. If the flag rotates more than half a turn without the spoke tightening then the nipple is probably stuck firmly on the spoke threads. Further turning can result in the spoke snapping. If you suspect the nipple is stuck then untwist the spoke and leave it. Try an alternative strategy such as tightening two adjacent spokes or even loosening an opposite side spoke. If all the spokes are impossible to adjust then the previous builder could have used permanent adhesive on the threads, if this is the case you have a major problem and if the out of true cannot be tolerated then it will need rebuilding with new spokes.

Note for Mavic built wheels. Mavic use a strong adhesive on their nipples that makes adjusting them very difficult. This problem is compounded because they invariably use straight pull spokes that offer no resistance when turning the wrench – they just spin around in the hub although gentle use of pliers to hold the spoke can sometimes work. The method I use to adjust a firmly glued nipple is to warm it gently using a cigarette lighter which breaks the adhesive bond sufficient to enable the nipple to be turned.

2. In the region of out of trueness and with no apparent loose spokes look for a tight spoke on the side of the wheel where there is deviation *towards* the brake block. Apply a flag and loosen the spoke, observe the flag since the spoke can just as easily twist as before and will require untwisting.

3. If all spokes appear to be similar in tension then by all means loosen one side and tighten the opposite, but first look for individual spokes that are slack, then look for those that are too tight.
4. If the wheel is in a bad state then you may end up adjusting the majority of the spokes in which case you will have to check the wheel dish (see *Wheel dishing* on page 50). It is also worthwhile stressing the wheel (see *Stressing the wheel* on page 52).
5. If you are attempting to true a wheel built by someone else then you may have to rectify some of their building errors. My first step is to try and equalise the spoke tensions before starting to fine-tune the trueness. Do not dive straight in and adjust spokes at random without giving careful consideration because you will no doubt make things a lot worse.
6. On a rear wheel the drive side spokes are much tighter and it is usually the case that a spoke on the *opposite* side will lose tension first. Note, only compare spoke tensions in the same side of a rear wheel.
7. Warning. If you remove the tyre and rim tape do not look into the rim channel while you tighten a spoke. A spoke that breaks can fly out of the rim and hit you in the eye.
8. If you are continually retrueing your wheel or replacing broken spokes then the initial wheel build is at fault. In this case it is better to dismantle the wheel, discard the spokes and rebuild using the correct technique.

## 6. Wheel Designs

The design of rims, hubs and spokes has evolved slowly over many years and they are now so well sorted that all components from the major manufacturers are capable of being built into top class wheels. This means you should never discount even the most humble of hubs and rims from lower down their product ranges because I hope you will have realised by now that the quality of the building determines the success of the resulting wheel.

Each year the component manufacturers will introduce new hubs and rims. They are obliged to do this to keep business ticking over and keep up with the others who are also introducing new products and the marketing material they issue makes it very tempting to believe there is good reason to “upgrade”. There may be other areas of the bike that benefit from advancement in design but there’s not much scope for reinventing the wheel. The spoke manufacturers are also battling to produce new spokes and as a result there are dozens of variations on a simple piece of stainless steel. As a wheelbuilder you are now in a better position to wade through the marketing material and select components based on function rather than cosmetic features or features that offer zero benefit to the performance of the wheel, and of course you will always be paying a premium for these additional *features*. By all means try new components and in time you will find those that work best for you, but I’d say start with ordinary hubs, rims and spokes first.

It is not possible to design for comfort other than choosing a wider rim that takes a wider and therefore softer tyre. The number of spokes, the type of spokes (plain gauge or butted) or the lacing pattern have no effect on ride comfort. A 3 cross wheel and a radial wheel with the same tyre and same pressure will be indistinguishable. A touring cycle may have a 4 cross wheel but that’s down to convention, to suggest that the longer (and more tangential) 4 cross spoke gives a more springy ride is wrong. A road race wheel may seem harsh but that’s a result of a narrow section tyre pumped up to over 100lbs pressure. This may be hard to accept that the tyre is the major influence on harshness of the ride so try a test yourself with a couple of wheels with different spoking patterns and spoke counts but make sure both have the same tyre and pressure. Ride one wheel then come back and repeat the ride with the other wheel.

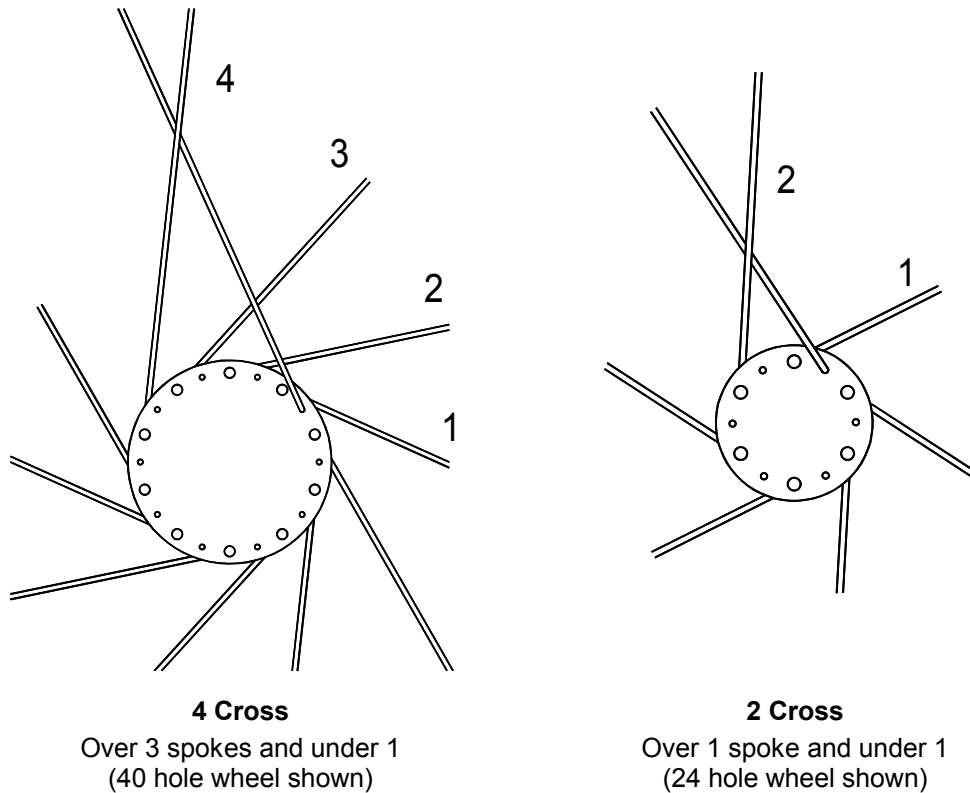
Don’t fall in to the trap that building your wheels with the lightest of lightweight components will make you go faster. Sorry but it won’t. When you add up the few grams saved it may sound an impressive figure (70g or whatever) but when compared to 80,000 grams of rider it sort of puts things in perspective (I weigh 80kg). If you want to go faster then train harder and mountain bike riders should also brush up on their bike handling skills. Actually a set of standard wheels (i.e. normal components) will allow you to ride faster because they will take more abuse without letting you down, plus you can ride harder down a rough track without having to worry about putting a few dents in your rims because they are cheap to fix (albeit a new rim will be required now and again).

If you want to make a stronger wheel then use a stronger rim. If you want long term durability to ride thousands of miles carrying heavy loads then use more spokes.

All that remains are lacing patterns and as a wheelbuilder you now have the option of lacing your wheel in a variety of patterns and not the stock 3 cross wheel you were normally provided with, so lets look at the options available to you.

## Standard crossed wheels

In the building section we built a standard 3 cross wheel which is one option from a family of crossed wheels. The other cross patterns available to you are 4 and 2 cross, and also zero cross (known as radial).



*Figure 52 Other standard cross patterns*

When counting the crosses remember that the first cross is very close to the hub and is often missed if you don't know what you are looking for.

To lace the wheel using 4 or 2 cross all you need do is make one change in Step 7 (figure 41) and use either the drawing for 4 or 2 cross shown above. You will of course require the appropriate spoke lengths because changing the crosses changes the spoke length.

When it comes to the number of crosses there is a recommended maximum for each drilling as shown in Figure 53. I've not included 40 hole hubs because I've not built any so cannot give a definitive recommendation and if I had to build one then I'd choose 3 cross.

Changing the cross pattern has no performance benefits but it does give you options on spoke length which may allow you to use up some spokes that you already have in stock.

Reducing the number of crosses uses slightly shorter spokes but any weight saving is negligible. With fewer crosses you will also get more acute weaving close to the hub.

Hub drilling	Preferred cross	Optional cross
36	3	4
32	3	2 (but try and use 3)
28	3 or 2 are equally preferred	
24	2	-

Figure 53 Hub drillings and preferred cross patterns

Lacing using the crosses shown in Figure 53 will ensure there is no over lapping of the spoke heads on the hub flange which puts an unnecessary bend and stress on the spoke at the elbow and it also makes replacing a broken spoke more difficult. The example in Figure 54 shows a 32 hole wheel and the relative positions of the spokes for 3 cross and the non preferred 4 cross.

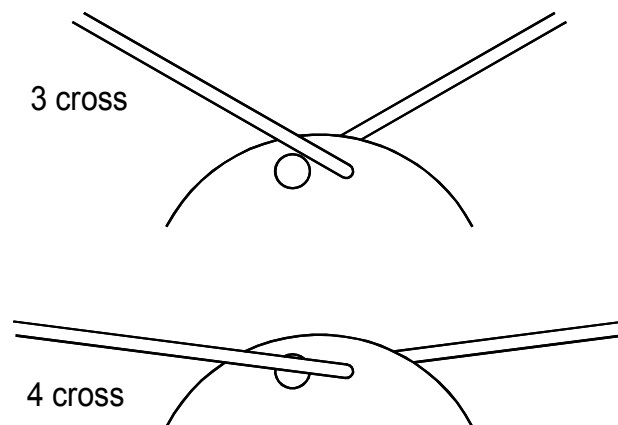


Figure 54 A 32 hole wheel built 3 cross and 4 cross

## Tying and soldering

Tying and soldering spokes where fine copper wire is wrapped around the spoke crossing points and then soldered in place is something I never do because I can see no benefits to this technique (it's not easy getting solder to stick to stainless steel). Some people may claim stronger wheels but I very much doubt it. Take a look at your new wheel and imagine wrapping a bit of flimsy copper wire around the crossing point of a pair of spokes, then adding a blob of solder – do you think it will make *any* difference to the strength or rigidity of that wheel? For track racing where the technique used to be popular many years ago one advantage was to keep a broken spoke in the wheel and allow the rider to complete the race, but nowadays modern quality spokes do not break as easy so there's no need to worry about tying and soldering. I've never even seen a tied and soldered wheel.

## Radial wheels

Radial lacing can be used on the front wheel, it can also be used on the rear wheel non drive side but **never** the rear drive side which needs the tangential design from a cross pattern to transmit the drive torque without the hub twisting in the wheel. For disc brake users you should never use radial on the disc side (front and rear) because that side needs to withstand the braking torque.

The radial pattern puts a lot of stress on the hub flange that can cause it to fatigue fracture when used over a period of time. For this reason many hub manufacturers do not recommend lacing their hubs radially and doing so could invalidate any warranty if the hub subsequently fails. If you look at a cross laced wheel then the stress on the hub from one spoke is counter balanced by an adjacent spoke pulling in the opposite direction and the more tangential the spokes (the more crosses) the less resultant stress there is on the hub.

The radial pattern has no spokes crossing and is straightforward to lace. It is usual to lace one complete side of the wheel at a time since there is no possibility of spoke tangles. The only decision on placing the spokes is whether to have the spoke heads on the inside or outside, or alternate them. There is no preferred technique but aesthetically the wheel may look better if all the spokes are placed with the heads on the outside. There is no performance benefit from using radial wheels but they do look different. If you plan to use a radial pattern then check with the hub manufacturer first to make sure they expressly say “radial allowed” since most do not.

## Cross combinations on the same wheel

You can use different cross patterns either side on a rear wheel. So you could for example do a rear 32 with 3 cross drive and radial on the other side – often referred to as half radial (if you plan to use radial then read the preceding discussion). It’s going to be interesting to build but no one other than another wheelbuilder is likely to notice. There are no performance benefits in doing this. Many people believe reducing the crosses on the rear wheel *non drive* side will improve overall wheel strength but this is wrong (if you thought about the geometry then reducing the crosses on the drive side is theoretically better).

If you choose to use a different cross pattern on the opposite side of the wheel then do not follow the lacing method exactly as shown in Step 4 on page 38 (placing the first spoke on the opposite flange). The procedure will need modifying slightly.

Figure 55 shows where to place the first spoke on the opposite side. This spoke will then dictate the placement of all the others on that side with little additional thought required by the builder. In the diagram *Normal* represents the standard placement when using the same number of crosses either side. For example if the near side is built 3 cross and you require 2 cross on the opposite side then place the spoke through the hole marked **-1** (i.e.  $3-1=2$ cross). For radial you would place it through the hole marked **-3** ( $3-3=0$  crosses, i.e. radial). The spoke is placed in the rim as previously described always to the left of the sighting spoke.

*[For type 2 rims rotate the numbers in the diagram clockwise one position and place the spoke in the rim to the right of the sighting spoke].*

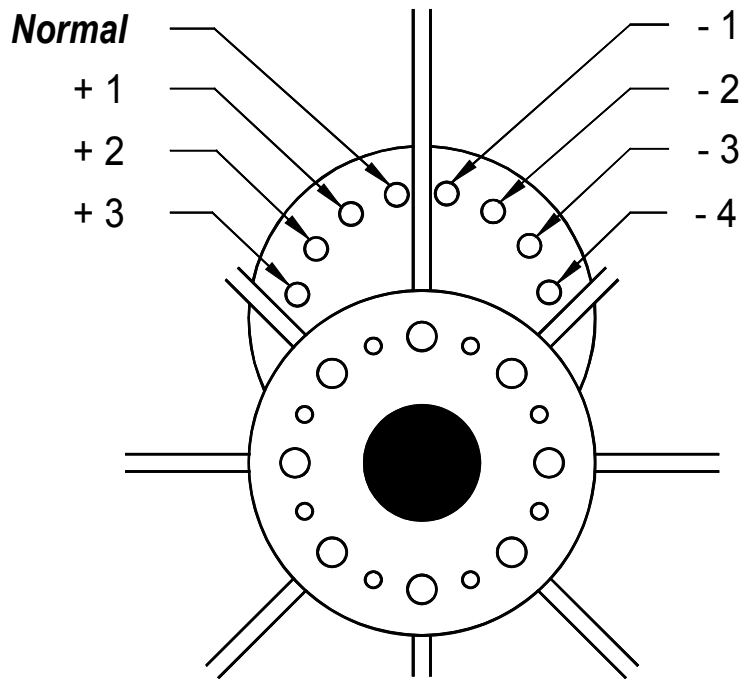


Figure 55 Different cross pattern on the opposite side - the first spoke

## Inside or outside pulling spokes

The pulling spokes on a crossed wheel can be arranged in one of four permutations as shown in Figure 56 (imagine looking down on a rear wheel at the pulling spokes leaving the hub flange). If you build your wheel using the instructions in this book then it will look like diagram A. All options will work and consequently you will see all options in use and the preference of the builder is more than likely based on the lacing method they were originally taught. I looked at wheels used in the Tour de France and most – then, were type A so I did it that way but it's not that important. Some theoretical people have their opinions on which option to use, for example wheels that transmit torque.

This reason is only applicable to the rear wheel that transmits the driving force (torque) and for front disc brake wheels that resist the braking torque since the discussion between which option is concerned with how the spokes react to the applied forces at the spoke crossing points. As torque is applied the spokes that transmit the forces will try to straighten and in doing so pull (or push) the other spoke at the crossing point either inwards or outwards (depending on the lacing orientation used). If they push outwards there is a chance of the spokes at the crossing point touching a closely positioned rear derailleur (ie. when using the largest sprocket) or front disc brake calliper. However on modern cycling components there is plenty of clearance and no chance of spokes touching them so it doesn't matter which option you choose.

If you understand the basics of lacing then switching between the options is easy, but do not get worried about which one to choose. Of the four, perhaps the symmetrical patterns of A and B are the most common and easiest to lace (to lace option B using the procedure shown in *Lacing the Wheel* on page 35, start with the hub the other way round i.e. in Step 1 place the spokes through the non drive side to start with).

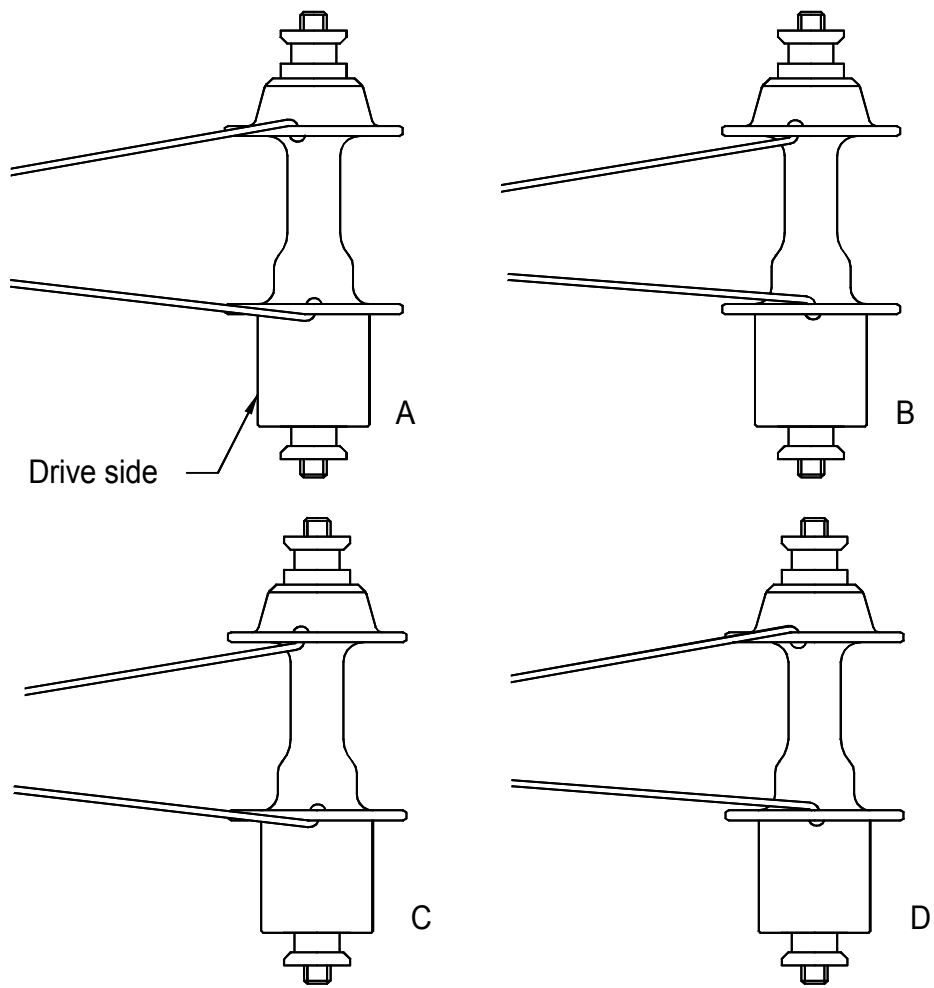


Figure 56 Inside and outside spoke orientations



Figure 57 A rear wheel built with option "A" spoking

## Other lacing patterns

As you become more interested in wheels you will be tempted to look at other lacing patterns but you should realise there is a good reason why you rarely see anything other than the standard cross pattern. There are other options for lacing a wheel, anything other than the standard cross pattern is likely to be cosmetic or an academic exercise only to show that “this could be possible” but with no useful benefits. Trawling around the Internet you will no doubt find strange lacing patterns and theories to back them up and often they only exist within a computerised drawing program or at best built up and rode a short distance. The thing is you never see any of these on real wheels and if there were a magic lacing pattern then we’d all know about it by now. Anyone remember the snowflake or twist lacing pattern that was popular for a year or so in the 90’s? So don’t mess with these alternate patterns or you will be asking for trouble (heed my warning at the end of this section).

## Missing out hub and rim holes

Not recommended. The hub and rim was designed to use the specified number of spokes to maintain its structural integrity and strength - so use them. Never build wheels by using less than the full complement of spokes in the hub and rim. If you want to use less spokes then get the appropriate components that were designed for that purpose.

## Number of spokes

Many of the wheel configurations have become standardised, so for a given application there will be a preferred wheel design whether this is for track, road racing, touring, tandems or off road. When it comes to designing your wheel take a look at what other riders use. In the majority of cases you will find 32 and 36 hole components built 3 cross and you will have to come up with a very good reason for doing something different. The exception to this is the heavier load carrying requirements of tandems that may need more spokes such as 40 or even 48 spokes. All my customer wheels for road sport/race, mountain bike and those of the professional downhill teams used 32 spokes.

## Design considerations - the Last Word

If I do have any advice then it is not to get side tracked with the many arguments for and against particular components or lacing patterns. Don’t lose sight of the original task which is to build a wheel that allows you to go out riding. What is more important is that you actually build something that you are satisfied with.

Use whatever components you want and in any colour you want and you’ll eventually discover your personal preferences. Just make sure reliability is top of the list.

For the record, and after building customer wheels using all sorts of permutations of components and after riding many options myself, my own personal choice is now a silver rim, a silver hub and 32 double butted spokes (2mm 1.8mm 2mm), brass nipples, laced 3 cross.

## Warning

Your competence as a wheel builder should never be assumed greater than it actually is. At all times remember that for a given rider and riding conditions **do not build anything that is potentially dangerous.**

Without specialist test facilities there is little the builder can do to confirm any theories other than ride the wheel and see what happens. This is not a wise choice. I don't risk my health and that of others and neither should you.

Braking hard at the bottom of a long fast descent is not the time to find out any deficiencies in your wheel design or building technique.

# 7. Spoke Lengths

Building wheels with the correct length spokes makes things so much easier. Building with the wrong length spokes can often mean the wheel will not build and you'll only realise this half way through the build sequence (or later if you don't recognise the symptoms early).

For me I want to get the spoke lengths correct because I don't want to waste time dismantling the wheel and starting all over again (commercial considerations). For you, you need the correct lengths because you are likely to be purchasing your spokes just for your one wheel and you don't want to be going back to purchase another set. And for both of us, the correct length spokes makes the building easy (or should I say easier).

However, even many good wheelbuilders struggle when it comes to selecting spoke lengths but it's not difficult at all. So it is worth spending some time to understand the techniques available. Here are the two techniques that I use.

## 1. A different hub

You have a hub that you've never built before.

Use the instructions in section 9 to measure your hub.

After measuring you might find that your new hub is geometrically similar to one you've previously built, in which case use the same spoke lengths (that you wrote down) for the previous wheel.

If it's your first wheel or the hub is significantly different to anything you've previously used, then:

Use the online spoke length calculator at [www.wheelpro.co.uk](http://www.wheelpro.co.uk)

I wrote this a long time ago and it has a cult following especially once you realise what it's all about. Too many people go there and just see a couple of little tables for hubs and rims and depart looking for a bigger database that miraculously might contain their wheel components.

Forget component names. All you are interested in are a few key dimensions and how to measure your hubs and rims. Learn the basics and you will always be able to calculate your spoke lengths regardless of what you build. So measure your rim and hub (sections 8 and 9) and pop the values into the calculator.

If you do some analysis using the spoke calculator and try changing the hub geometry you will realise that dimensional changes do not have a major impact on the resulting spoke lengths which means for spoke length purposes there are lots of "similar" hubs from across many manufacturers. Rim diameter has the biggest influence and a 20mm increase in diameter would make the spokes virtually 20mm longer.

Now here's the important bit. **Write things down** and keep your records safe for future use. You need to record the name and dimensions of the hub and rim and the spoke lengths used.

When you build your wheel always examine it to see how the spokes finished up. The ideal length is when the top of the spoke finishes flush with the top surface of the nipple although 1mm above or below is equally acceptable. The worst cases are when the spoke threads are visible beneath the nipple, definitely too short and unsightly, plus they have minimal thread engagement, or when the spokes are too long and protrude through the nipple and foul the rim tape, although neither should happen if you measure your components accurately. If your spokes appear to be a little short or long then make a note and compensate for this when building a similar wheel in the future.

Using spokes that differ in length by 1mm (over or under) from the preferred length will not cause any problems and you may have to make this compromise when purchasing spokes. Spokes are generally manufactured in 1mm increments but many shops do not stock the complete range, some only stocking even sizes, and some spokes are only made in 2mm increments.

When I write my information down I always examine the finished wheel then write down two sizes. The first is the preferred size and the other an alternate size that would still build the wheel. This gives me the option of saying in the future *"well I haven't got that size in stock, but I know the alternative will work just as well"* and if I knew the alternative was say 1mm longer I would know this when building the wheel and give the nipples a few extra turns when taking up the initial slack.

## 2. A different rim (on a hub you've previously built)

You've previously built a wheel using this hub but now you want to replace the rim or build another wheel using that uses the same hub (same number of spokes and same lacing pattern) but on a different rim.

Compare the rim diameters

Once you have built a wheel then selecting spokes for any rim using the **same hub** is easy.

For example, I have already built a wheel using rim xyz and the spokes I used (which I wrote down when I built it) were 262mm. The next wheel I am going to build uses the same hub but this time using a totally different rim which I have never used before - so what spokes should I use?

The previous rim measured 540mm in diameter (you wrote this down when you built it and are now referencing your notes), the new rim measures 544mm in diameter so the spokes for this rim are 2mm longer and I will use spokes at 264mm (providing I'm using the same cross pattern and same drilling).

All I did was measure my new rim then use half the difference in rim diameters to modify my existing spoke lengths. Obviously if my new rim was smaller in diameter I would be subtracting rather than adding.

Use the instructions in section 8 to measure your rim.

You only need one reference pair of wheels per hub for comparison purposes and the technique is accurate for all rims even where there is a large discrepancy in rim diameters. I use this method all the time and a good example was at the Future Publishing *Bike* shows. I was on the Sapim stand where we offered a wheel build service for people who purchased hubs and rims at the show. The hubs were all something I'd built before (or a similar geometry to something I had previously built) but I'd get all sorts of different rims that I'd never seen before. All I did was measure the diameter and compare it to something I'd built before. No computers required and I never got a spoke length wrong in all the shows.

Learn to use the comparison technique since many hubs these days, particularly road hubs and most mountain bike hubs, have a common geometry. For example every Shimano hub with the exception of disc brake models are identical, so for spoke length purposes a Shimano 105 is identical to a Shimano DuraAce. The exception are mountain bike disc brake hubs which all seem to be different.

If you do have a hub with a geometry you are not familiar with or you have the same hub but in a different drilling or require a different cross pattern then it's best to use the online calculator. However, once you have determined the spoke lengths they then become your standard for this hub and for other rims just compare rim diameters to the one just built.

The techniques described above required you to measure your components - you need to write these down. When you build the wheel examine how the spokes finished up then write down the exact spoke lengths for the specified wheel. In the future this will become some of the most valuable wheelbuilding information you have and believe me, you will kick yourself if you didn't record your data.

## The spoke length formula

If you want to create your own calculator then you'll need the spoke length formula. Some people like to use a spreadsheet and I know someone who has it loaded up on his personal hand held computer.

For completeness, the proof of the formula is given later.

$$\text{Spoke Length} = \sqrt{R^2 + H^2 + F^2 - 2RH \cos\left(\frac{720}{h} \cdot X\right)} - \frac{\phi}{2}$$

where :

*R = Rim radius to spoke ends*

*H = Hub radius to spoke holes*

*F = Flange offset (dimensions C and D on page 85)*

*X = Cross pattern*

*h = Holes in rim*

*φ = Diameter. of spoke hole in hub*

*Figure 58 The spoke length formula*

Notes when using the formula

1. Take accurate measurements from your hub and rim (refer to Sections 8 and 9).
2. Many spreadsheets use angles in radians for their cosine function. The value used in the formula is in degrees so make the necessary conversion if required by multiplying by  $2\pi/360$  to obtain the value in radians.
3. Check a trial calculation using the worked example on the next page. It is easy to make errors that will yield acceptable looking spoke lengths but you will only find they are wrong when you start building the wheel.
4. For the same hub and rim there are a number of drillings and cross patterns that yield the same spoke lengths, for example :  
  
2 cross 24 are identical to 3 cross 36.  
1 cross 16 are identical to 2 cross 32
5. For radial wheels the number of crosses in the calculation is zero giving identical spoke lengths regardless of the number of holes.

## Using the Formula

For example purposes a 540mm diameter rim is used and a Shimano small flange front hub with 32 holes built 3 cross.

R	270
H	19
F	36
$\phi$	2.3

Substitute these values into the spoke length formula in Figure 58.

$$\text{Spoke length} = \sqrt{270^2 + 19^2 + 36^2 - 2 \times 270 \times 19 \times \cos\left(\frac{720}{32} \times 3\right)} - \frac{2.3}{2}$$

$$\text{Spoke length} = \mathbf{264.6\text{mm}}$$

In this case I always round down and so would use 264mm. The formula assumes everything in the wheel is rigid. However, spokes stretch a little and rims compress a little so you are better to round the theoretical lengths down.

## The online calculator

In the online spoke calculator ([www.wheelpro.co.uk](http://www.wheelpro.co.uk)) I actually programmed it to knock 0.5mm off all spoke lengths which is a good compromise and made the results more accurate in the “real world”.

If you are checking this calculation with the spoke calculator then A and B = 38, C and D = 36 and rim diameter = 540.

## The spoke length formula proof

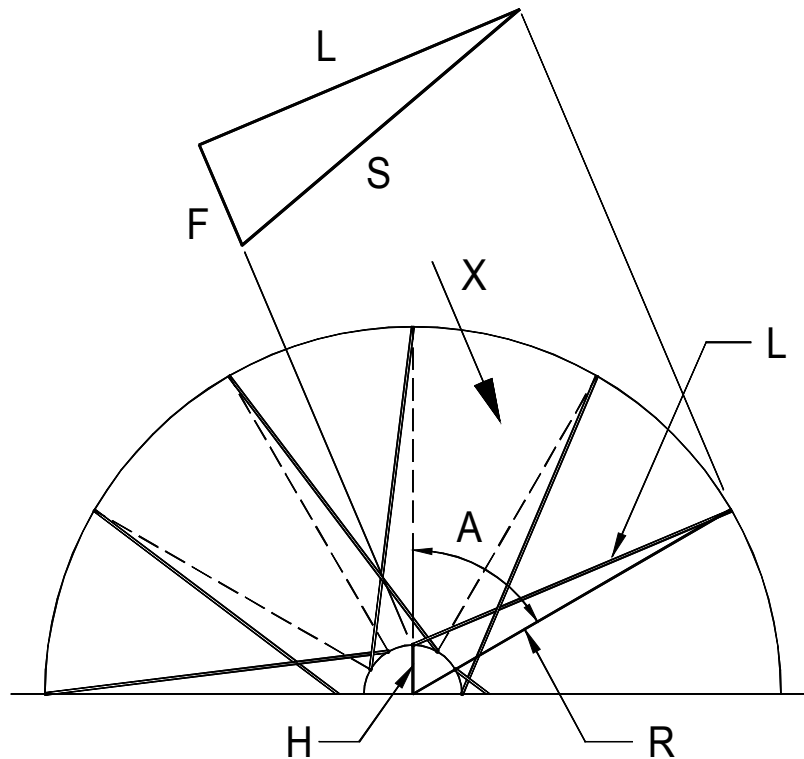


Figure 59 The geometry of a 24 hole 2 cross wheel

Look at the spokes in one side of a wheel (Figure 59) and consider the triangle with sides  $H, L, R$  with included angle  $A$  where :

$L$  = Intermediate length

$R$  = Rim radius (to spoke ends)

$H$  = Hub radius (to spoke holes)

Using the *Cosine* rule

$$L^2 = R^2 + H^2 - 2RH \cos A \quad (1)$$

Now take into account the 3 dimensional construction, with the spokes joining the hub at the hub flanges i.e. looking in direction  $X$  on Figure 59.

$$S^2 = L^2 + F^2 \quad (2)$$

where:

$S$  = Spoke length

$F$  = Flange offset (dimensions  $C$  and  $D$  on page 85)

Substituting  $L^2$  from (1) into (2) gives

$$S^2 = R^2 + H^2 + F^2 - 2RH \cos A$$

and

$$S = \sqrt{R^2 + H^2 + F^2 - 2RH \cos A}$$

This gives the spoke length to the centre of the hub hole. Spoke lengths are measured to the bend of the spoke which rests on the edge of the hub drilling so half the spoke hole diameter in the hub must be subtracted.

$$S = \sqrt{R^2 + H^2 + F^2 - 2RH \cos A} - \frac{\phi}{2} \quad (3)$$

where  $\phi$  = the diameter of the hub drilling.

The angle "A" depends on the cross pattern and the number of holes on the hub flange. Study Figure 59 (and Figure 66 on page 89) and note how the angle changes with cross pattern. Each cross takes up one sector.

If  $h$  = total holes in the rim

Then the number of sectors on the hub flange =  $\frac{h}{2}$

$$\therefore \text{Angle in one sector (degrees)} = \frac{360}{\frac{h}{2}} = \frac{720}{h}$$

For any cross pattern  $X$

$$A = \frac{720}{h} \cdot X \quad (4)$$

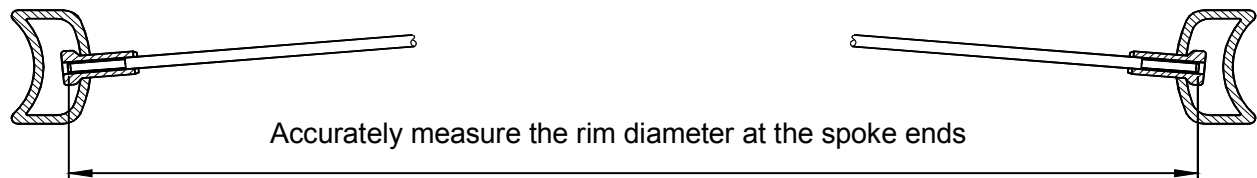
Substituting (4) into (3) gives the general spoke length formula.

$$\text{Spoke Length} = \sqrt{R^2 + H^2 + F^2 - 2RH \cos\left(\frac{720}{h} \cdot X\right)} - \frac{\phi}{2}$$

where :  $R$  = Rim radius to spoke ends       $h$  = Holes in rim  
 $H$  = Hub radius to holes                   $X$  = Cross pattern  
 $F$  = Flange offset                               $\phi$  = Dia. of spoke hole in hub

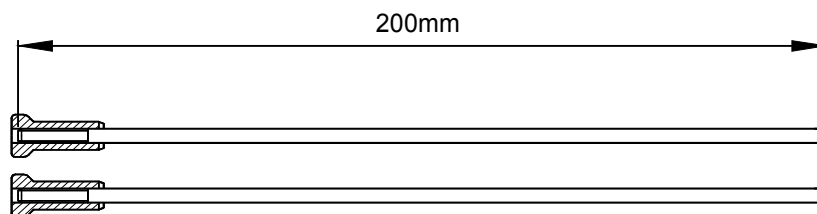
## 8. Measuring rims

The only rim dimension that matters for spoke length purposes is the *over spoke* diameter (sometimes referred to as the Effective Rim Diameter ERD), all other profiles and rim dimensions are irrelevant. You must measure the diameter *before* lacing the wheel.



Rim diameter has the **biggest effect** when calculating spoke lengths so measure it **accurately**.

This is how you do it. Take two spokes and cut them down accurately to 200mm. Screw down the nipples so that the spoke ends are flush with the bottom of the slot and glue in position. I always kept a set of these in my toolbox.



Now place these spokes in opposite sides of the rim and measure the gap between the ends. Add 400mm to get the rim diameter. Average several diameters.

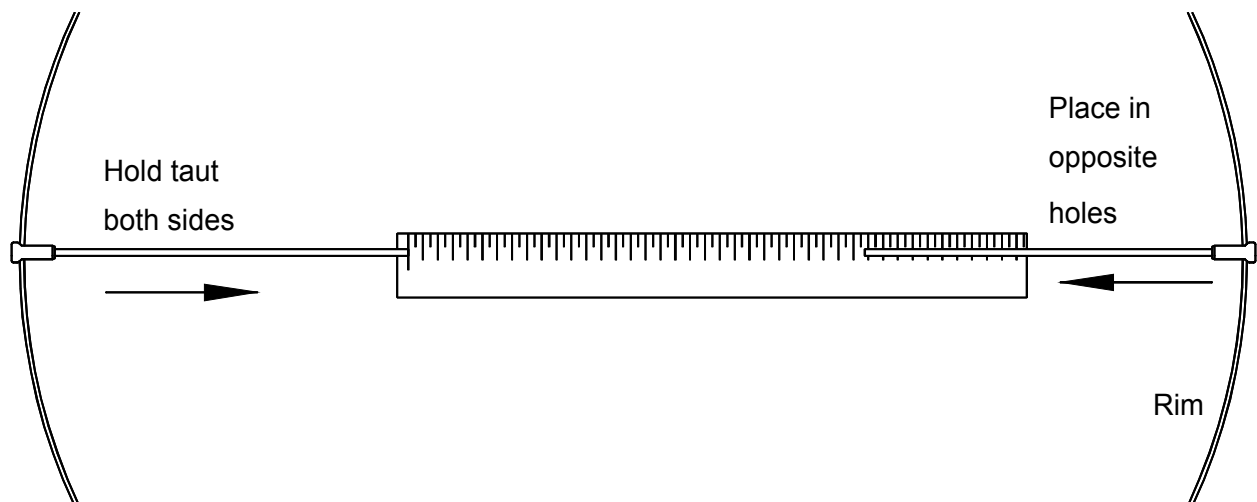


Figure 60 How to measure the rim diameter



## 9. Measuring hubs

As with the rims there are only a few key dimensions on the hub that are required for spoke length purposes.

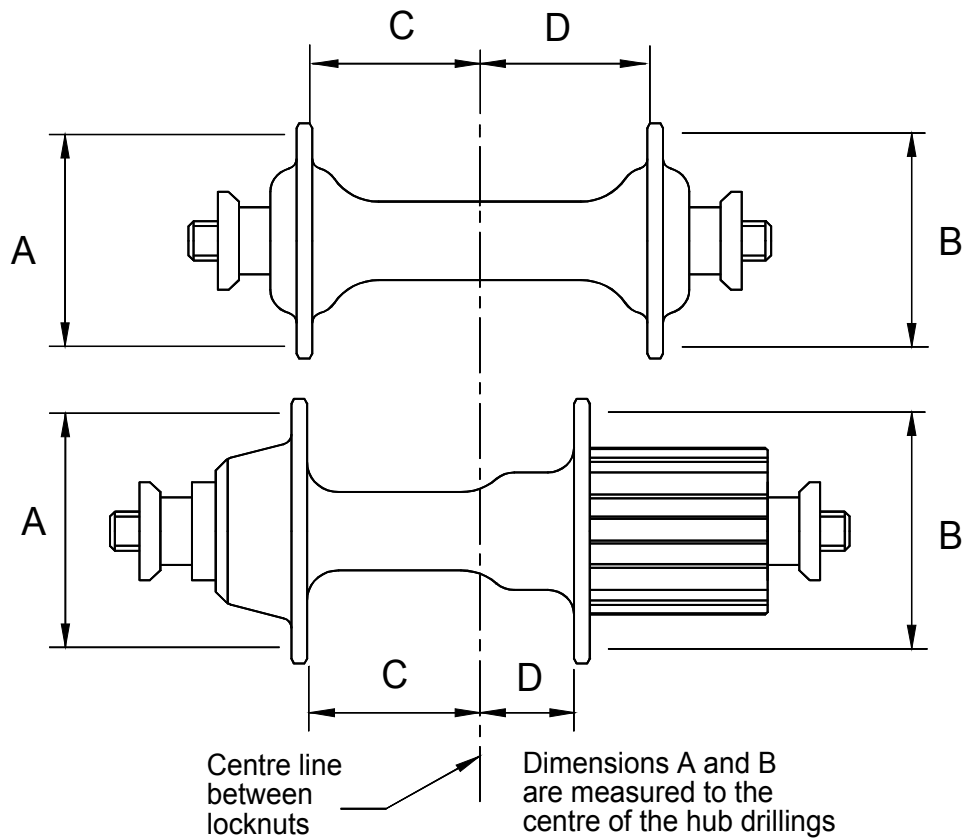
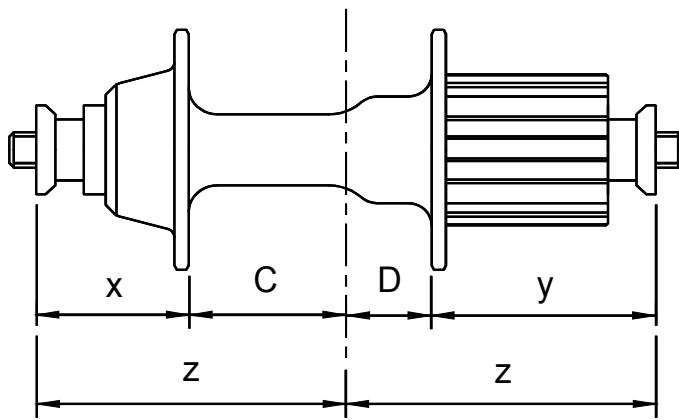


Figure 62 Key dimensions for a pair of hubs

The dimensions A, B, C and D also relate to the data entry boxes at the online spoke calculator at [www.wheelpro.co.uk](http://www.wheelpro.co.uk)

### Measuring your own hubs

With standard symmetrical front hubs obtain dimensions C and D by measuring across the hub flanges and divide by two (C and D being identical). For the rear and front disc hubs use the following technique to measure dimensions C and D.



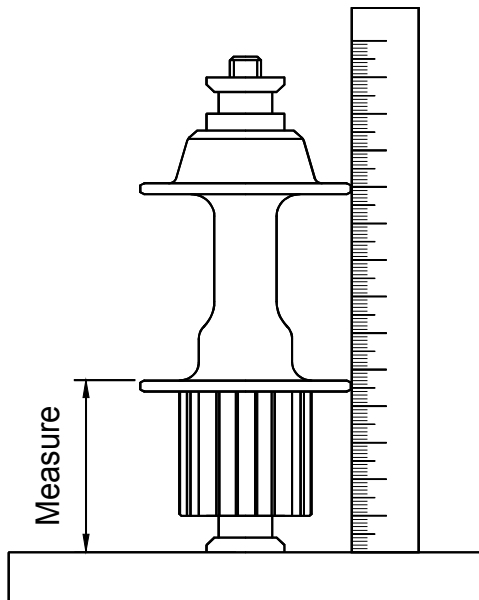
First measure x and y  
(see below)

Then :

$$C = z - x$$

$$D = z - y$$

$z =$  Half the over locknut  
dimension



### Measuring x and y

To gain greater accuracy when measuring x and y, drill a piece of wood and let the hub stand upright on its locknut. Take the measurement then turn over and repeat.

If the hub flange diameters are a different size then using a ruler is impractical (try it and see why). Instead use a piece of card and mark the position then measure separately.



Figure 63 Measuring the rear hub

**Always** record your measurements for future reference. The table on the next page is provided for this purpose.

### Hub data sheet

Measure the dimensions A, B, x, y.

Use your ruler to measure the distance between the flanges – dimension F in the table below.

Now calculate C and D where:

$$C = z - x$$

$$D = z - y$$

Check your values since  $C + D$  should be the same as F.

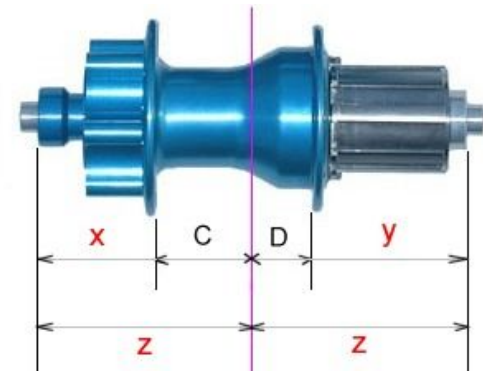
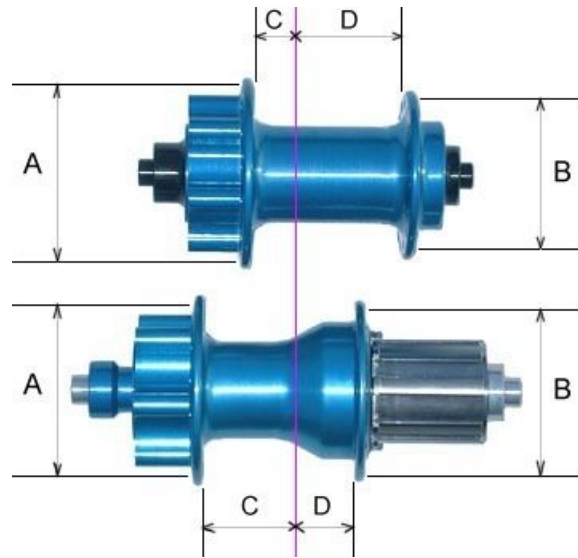


Figure 64 Hub data

Name	A	B	C	D	x	y	z	F

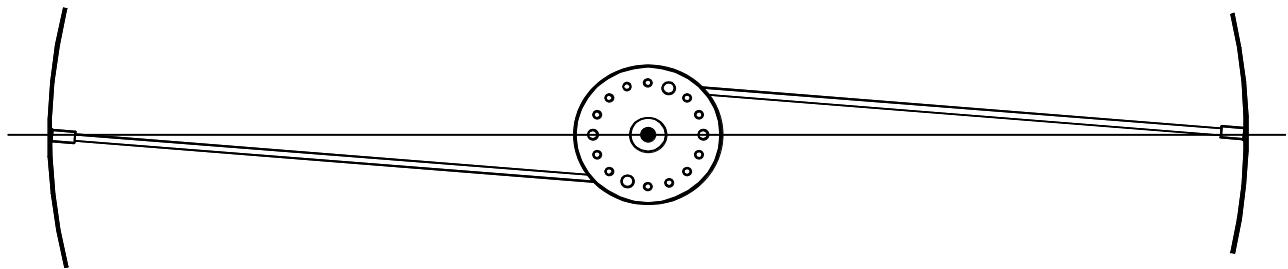
## 10. The Geometry of a wheel

The discussion on geometry presented here is for builders who would like to sketch their own wheels or draw them to scale using a computer draughting program.

If you are reading this on-screen then the diagrams may not appear too precise, if you print out the pages then they will be pin sharp and a lot clearer.

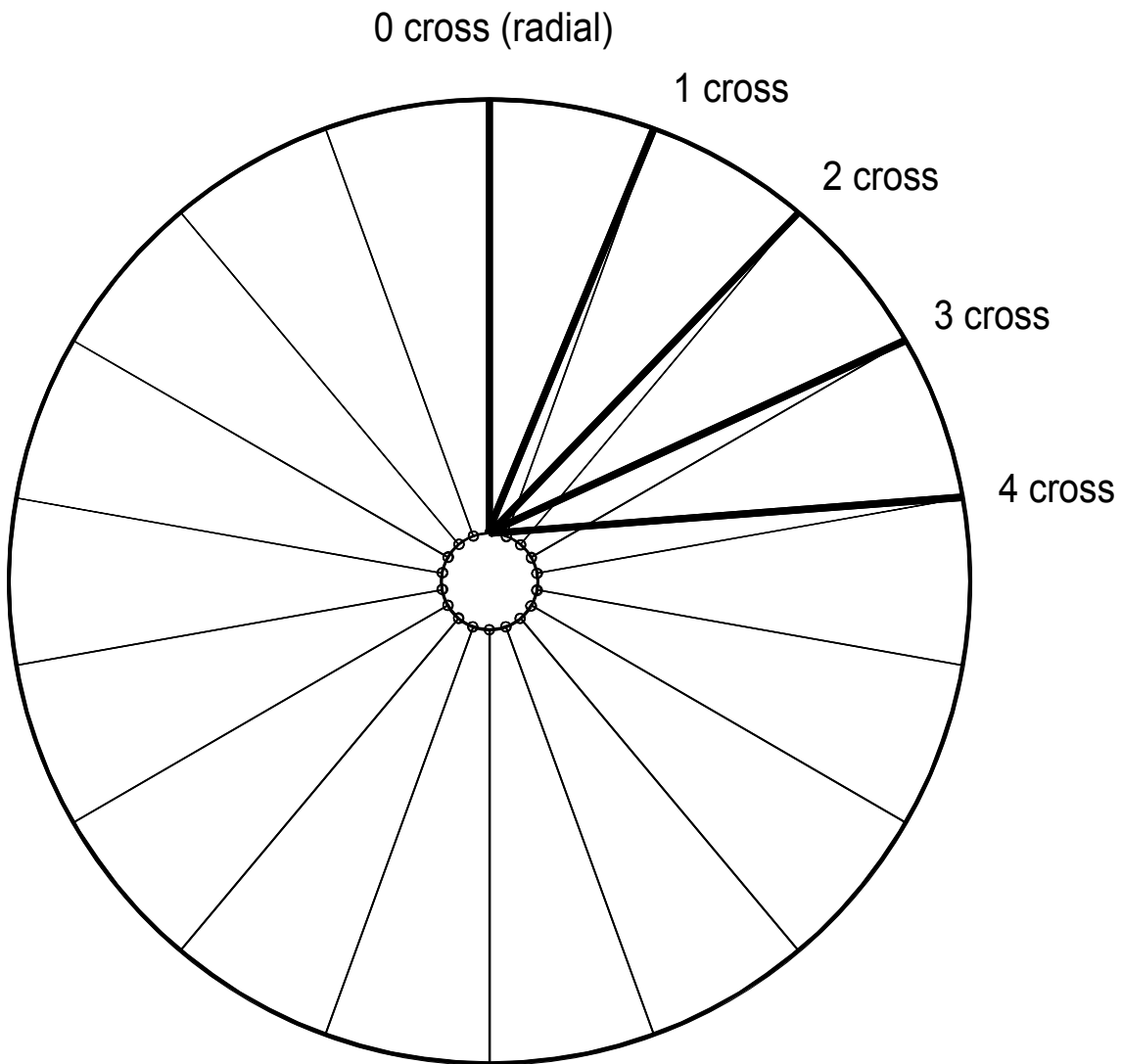
The construction of a wheel may appear complex but with the aid of simplified diagrams a regular geometric pattern is easily identified. For reference purposes when studying the following diagrams get hold of a completed wheel (not a radial one) with the skewer removed and a fine piece of string.

Look at one side of your wheel and completely disregard the spokes on the other side since each side can be considered in isolation. The key to understanding the geometry is to notice how holes in the hub flange are aligned radially with the holes in the rim. This can be seen on your reference wheel by stretching a piece of string across the wheel diameter passing it over the hub centre and over a hole in the hub, observe how it intersects a rim hole on the *same* side.



*Figure 65 The alignment of hub and rim holes*

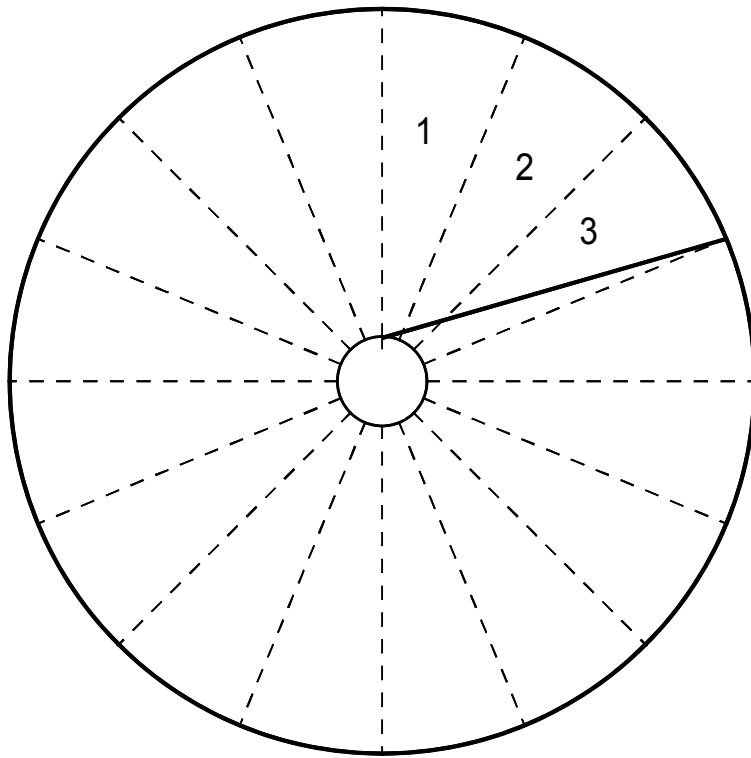
The diagram in Figure 66 shows the placement of a single spoke for the various cross patterns. To clarify the diagram, we are using the same hole in the hub and extending to different positions on the rim. The radial guidelines align with the hub and rim spoke holes. Only one side of the wheel is shown. As can be seen, a more precise definition of the term *cross* is the number of sectors crossed when the spoke is connected between the hub and rim. A 36 hole wheel is drawn but the procedure is just the same for the other standard drillings.



*Figure 66 The placement of spokes in a crossed wheel*

### **How to draw a wheel**

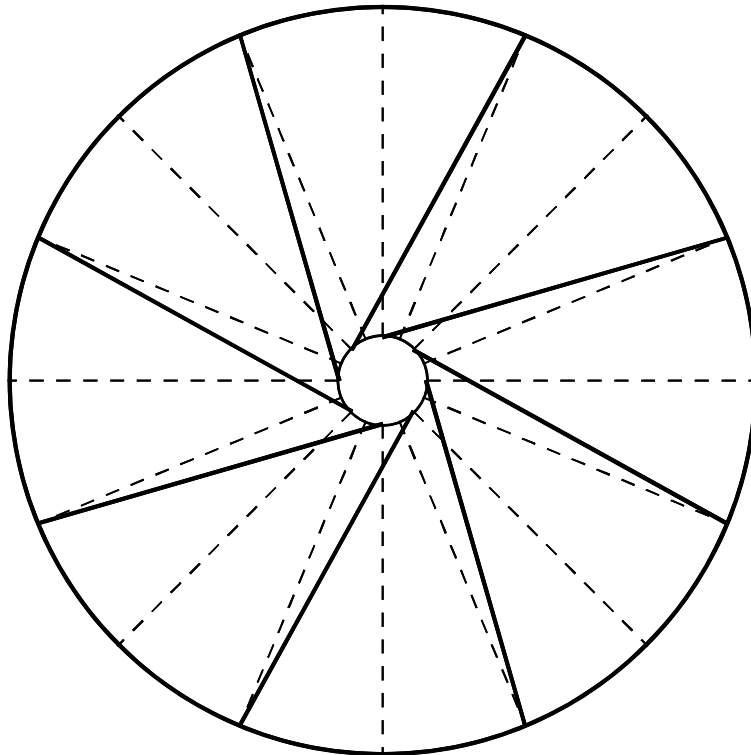
The following diagrams show you how to draw a 32 spoked, 3 cross wheel. It is only necessary to draw one side because the opposite side is identical but rotated half of one hub hole pitch. The same technique is used for all other drillings and cross patterns (for cross patterns other than 3, modify the first step).



### Step 1

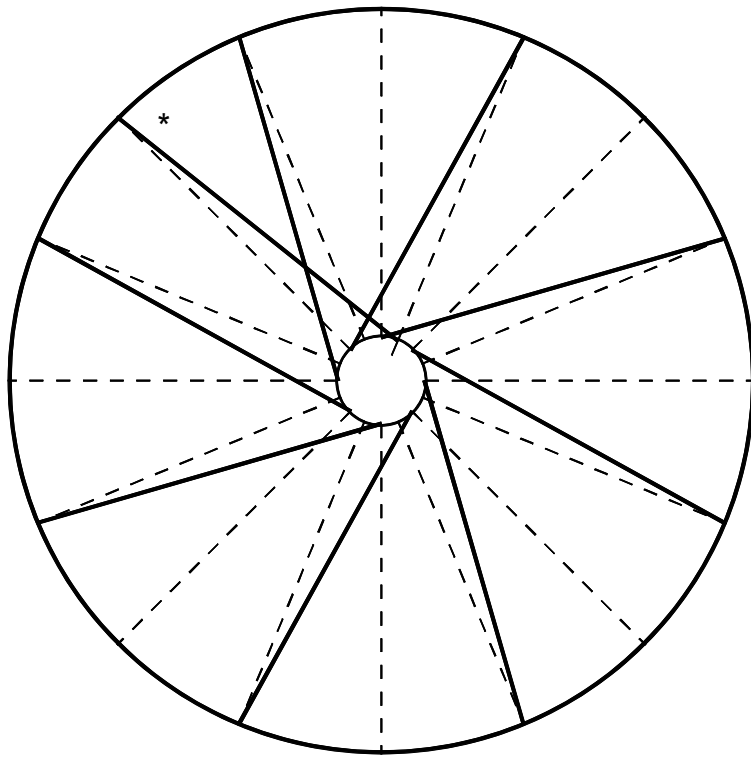
The first spoke is shown in position.

Since it is a 3 cross wheel the spoke crosses 3 sectors before entering the rim.



### Step 2

This spoke is now replicated 8 times.

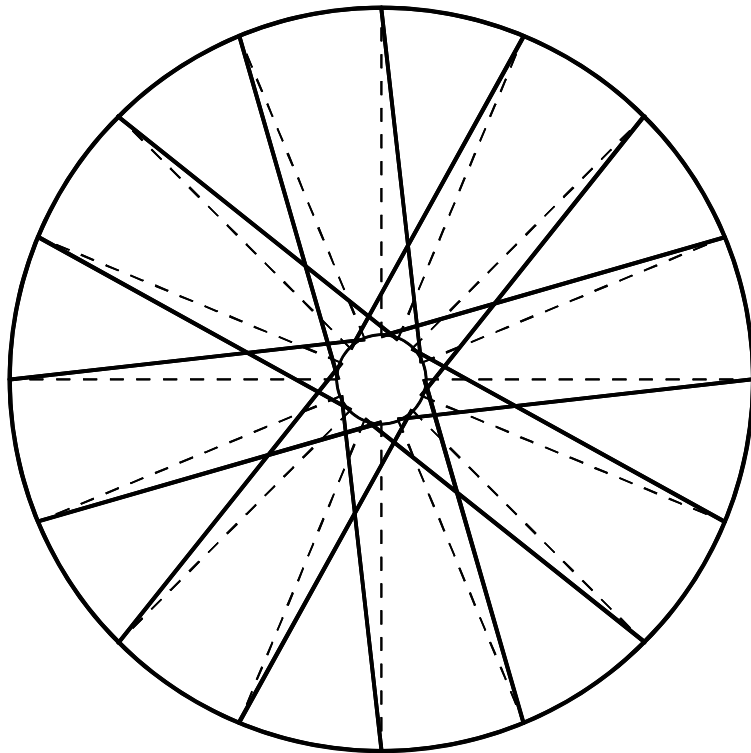


### Step 3

The first spoke in the opposite direction is now in place (marked \*).

It too crosses 3 sectors before entering the rim.

It actually crosses 3 other spokes which is the normal way of describing *cross pattern*. The first spoke it crosses is very close to the hub and is often missed when counting crosses on a built up wheel.



### Step 4

The wheel with one side drawn.

Take a look at the wheel in Figure 42 on page 43 which has both sides laced and was drawn using the technique shown here.

What appears to be a complex arrangement is in fact quite a simple repeating pattern.

Figure 67 How to draw a wheel

# 11. Wheel building checklist

## 1. **Preparation and Lacing** *(page 35)*

Oil the rim eyelets and spoke threads. Lace the wheel making sure you get the first spoke correct to ensure the valve hole ends up in the correct place.

## 2. **Start taking up the slack** *(page 46)*

Tighten the nipples using the nipple driver to take out the initial slack. If they are still very loose then tighten a couple of turns with the wrench. The spokes must not be tight.

## 3. **Align the spokes** *(page 47)*

Press down any bows in the spokes at the hub flange.

## 4. **Take up all of the slack** *(page 47)*

Start using the spoke wrench. Take care to always turn it in the correct direction.

The spokes will make a tone when plucked close to the nipple.

## 5. **Improve the lateral trueness** *(page 47)*

Make the wheel laterally true, the closer the better.

## 6. **Adjust the radial trueness** *(page 48)*

Make the wheel radially true.

## 7. **Equalise the spoke tensions** *(page 49)*

The spokes should have the same tone when plucked. Only compare tensions on the same side on dished wheels.

## 8. **Check the wheel dish** *(page 50)*

Take out the big errors and check regularly from now on to maintain dish.

## 9. **Final tensioning** *(page 53)*

Watch out for spoke twist *(page 51)*

Remember to stress the wheel *(page 52)*

## 12. And finally...



What I have done is show you *everything* I do regarding wheelbuilding and answered the questions that I was asking when I started building wheels. I haven't kept back any *secrets* and you know as much as I do.

If you think I haven't covered a particular aspect of building, whether in components or techniques, then it's because I do not use them. For example, mountain bike tubeless rims are not covered in this book, the reason being that when I was in commercial wheelbuilding they were not on the market until a year after I moved on. So I've never built one, never even seen one and I'll leave them for you to sort out. However, once you have a good grounding in the fundamentals then you will be able to tackle anything wheel related.

You can read many other articles on wheelbuilding and listen to many others discussing wheels but always question what you read and hear and form your own opinion and not take anything at face value. Perhaps most important of all be critical of your own building skills and learn from your mistakes.

I hope that you are soon riding on a pair of your own hand built wheels and are not overwhelmed by the detail presented in this book. Very soon you will wonder what all the fuss was about as building wheels becomes second nature. But it does take time and each wheel you build will be better than the previous one.

It's how far you want to take it really, whether it's just a pair of wheels every couple of years or getting withdrawal symptoms if you haven't tinkered about with a wheel in the last couple of weeks.

You may even consider going into professional wheelbuilding but I'd advise not even thinking about it. Remember that I've been there, done it (at quite a high level) and got out! These days you are unlikely to make a decent living solely from wheelbuilding. You need some other product to complement your building activity and for me that was disc brakes. It was advent hydraulic disc brakes in the 90's that persuaded me that the time was right to start up in business. Riders wanted disc brakes and they all needed new wheels to accept disc rotors. So I took on a business unit in Preston UK and started building high specification wheels and also sold the brakes themselves. The *Hope Technology* factory was not too far from Preston and I soon had a good working relationship with the guys there and quickly learned lots about disc brakes eventually writing their disc brake user guide in 2000 which still forms the basis of their current user guide.



At weekends I was usually found doing race service at downhill MTB events due to the sponsorship deals I struck up with some of the big teams whereby I built all their wheels and looked after them in return for some good publicity.

Everything was going well and according to plan. However as time progressed more people had done their disc brake upgrades and the brakes were often supplied as original equipment, plus there were more people selling brakes. So my brake selling activity (my big earner) was not as buoyant as it used to be and more people were selling “handbuilt wheels” often much cheaper than mine (I could drop the quality and build down to a price but didn’t want to). Road race wheels were good to build but people with the larger budgets were increasingly taking the factory pre-built wheels from the likes of Mavic and Campagnolo leaving me with the low spec training wheels. I was being squeezed from all angles.

You’d be correct in thinking that I failed to react to the way the market was moving but I didn’t want to get into pure retail. So I decided to move on and left the wheel business and everything cycling related. These days I build the occasional wheel for friends and family.

So I’d say just build wheels for yourself and continue to enjoy your cycling and be very careful about taking your wheelbuilding activities further.

In writing this book I was tempted to write everything in the past tense, “*I used...*” but decided to use the present tense “*this is what I use*”. Who knows what the future holds.

All the best,

Roger

Please note, this book is not “free”. If you are reading a copy that you obtained without paying please go to [www.wheelpro.co.uk](http://www.wheelpro.co.uk) and make a purchase, it’s not expensive and you will be ensuring that you are using the most up to date copy. Thanks.